



UNIVERSITI SAINS MALAYSIA

**EEE 241**  
**ANALOG ELECTRONICS 1**  
**TUTORIAL**

**DR NORLAILI MOHD NOH**

---

1.

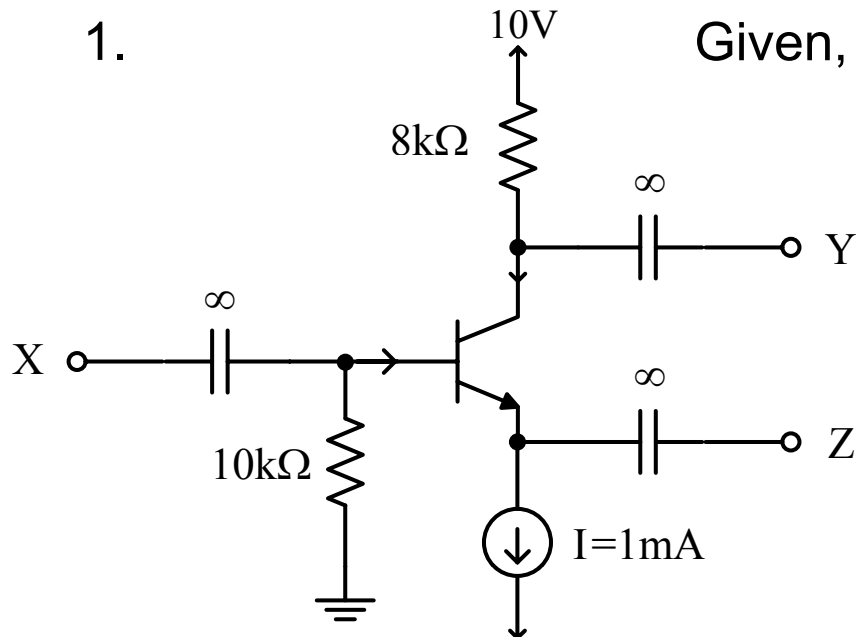

Given,  $\beta_o = \beta_F = 100$

$V_T = 26\text{mV}$ ,  $V_A = 100\text{V}$

$V_{BE} = 0.7\text{V}$

(a) Determine the dc voltages at the 3 terminals of the BJT ( $V_B$ ,  $V_C$ ,  $V_E$ ).

(b) Determine  $g_m$ ,  $r_{\pi}$  and  $r_o$  ?

(c) Determine the voltage gain ( $v_Y / v_s$ ) of this amplifier circuit if a signal source with a voltage  $v_s$  and a  $2\text{ k}\Omega$  internal resistor is connected to X and an  $8\text{ k}\Omega$  load resistor is connected to Y. Z is connected to ground.

(d) If the  $r_o$  is neglected, calculate the percentage of error in your calculation of the voltage gain.

a) dc voltage at B, E and C.

$$I_E = 1\text{mA} \quad I_C = \alpha I_E = \frac{\beta_F}{\beta_F + 1} I_E = 0.99\text{mA}$$

$$I_B = \frac{I_C}{\beta} = \frac{0.99\text{mA}}{100} = 9.9\mu\text{A}$$

$$V_C = 10 - I_C R_C = 10 - 0.99\text{mA}(8\text{k}) = 2.08\text{V}$$

$$I_B = \frac{0 - V_B}{10\text{k}} \quad \therefore V_B = -9.9\mu\text{A}(10\text{k}) = -0.099\text{V}$$

$$V_{BE} = V_B - V_E = 0.7\text{V} \quad \therefore V_E = -0.099 - 0.7 = -0.799\text{V}$$

b) Given:  
 $\beta_o = \beta_F = 100$   
 $V_T = 26\text{mV}$   
 $V_A = 100\text{V}$

Calculated:

$$I_C = \alpha I_E = \frac{\beta_F}{\beta_F + 1} I_E = 0.99\text{mA}$$

$$g_m = \frac{I_C}{V_T} = \frac{0.99\text{m}}{26\text{m}} = 0.0381\text{A/V}$$

$$r_\pi = \frac{\beta_o}{g_m} = \frac{100}{0.0381} = 2624.6719\Omega$$

$$r_o = \frac{V_A}{I_C} = \frac{100}{0.99\text{m}} = 101010.101\Omega$$

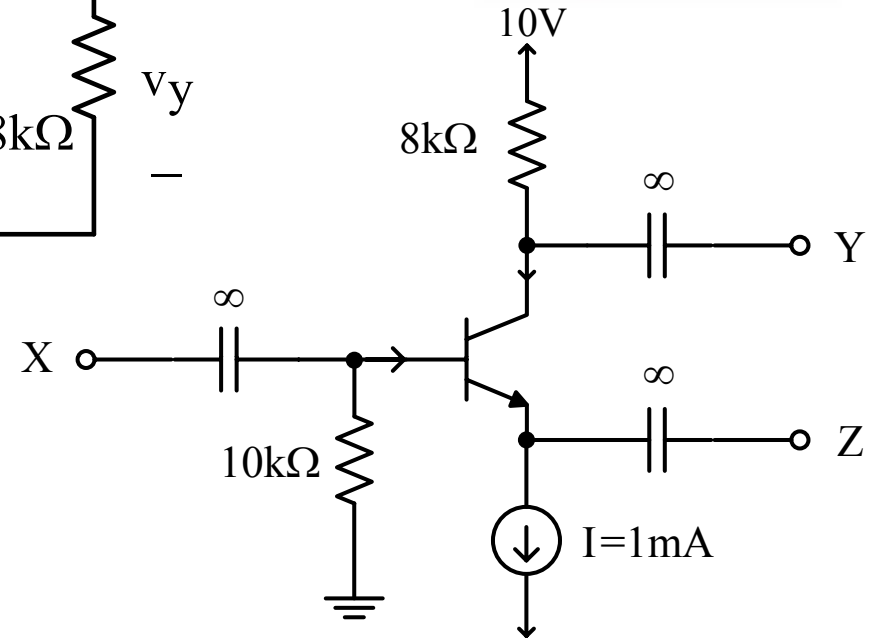
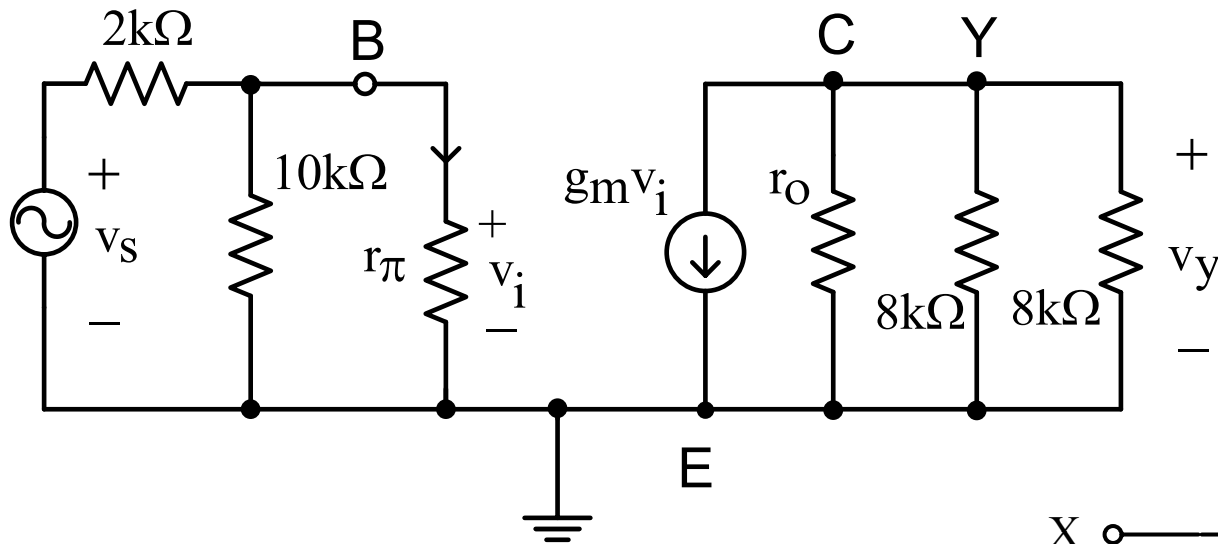

$$\begin{aligned}
 \text{c) } a_V &= \frac{v_Y}{v_s} = -\frac{g_m v_i r_o // 8k // 8k}{v_s} \\
 &= -\frac{g_m \frac{(r_\pi // 10k)v_s}{2k + r_\pi // 10k} (r_o // 4k)}{v_s} \\
 &= -0.0381 \left[ \frac{2079.0021}{4079.0021} \right] 3847.6337 \\
 &= -74.717
 \end{aligned}$$

$$\begin{aligned}
 g_m &= \frac{I_C}{V_T} = \frac{0.99\text{m}}{26\text{m}} = 0.0381 \text{ A/V} \\
 r_\pi &= \frac{\beta_o}{g_m} = \frac{100}{0.0381} = 2624.6719 \Omega \\
 r_o &= \frac{V_A}{I_C} = \frac{100}{0.99\text{m}} = 101010.101 \Omega
 \end{aligned}$$

d) If  $r_o$  is neglected,  $A_v = -0.0381(0.5097)4k = -77.6783$

Hence, the percentage of error  $= \frac{77.6783 - 74.717}{74.717} \times 100\%$   
 $\approx 3.96\%$

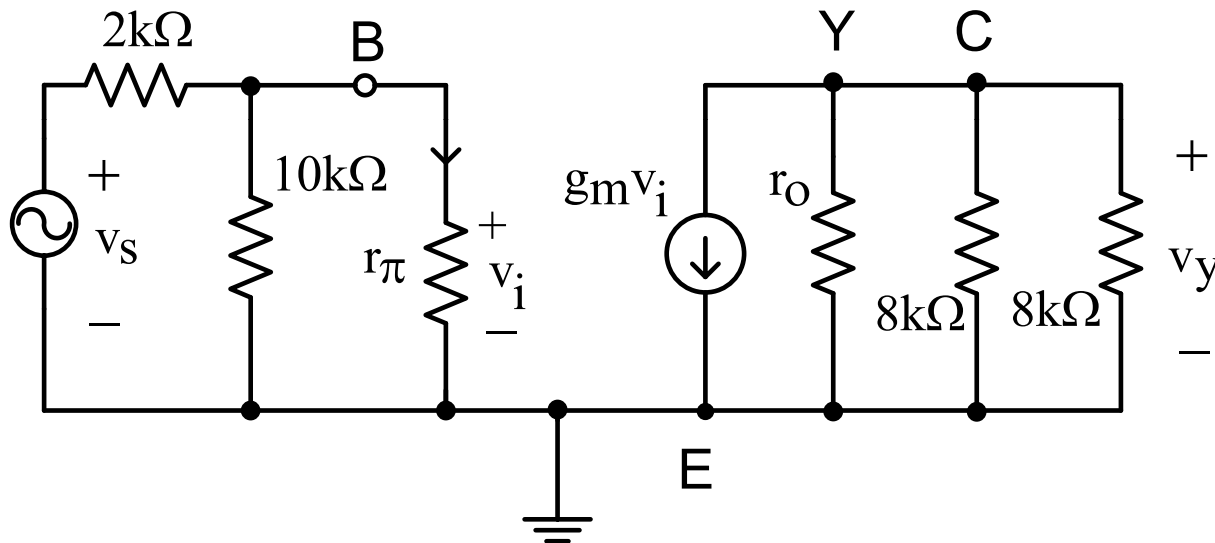

2. Determine the signal voltage at the B. The signal source gives a voltage of 10mV rms and has a resistance of 300Ω.

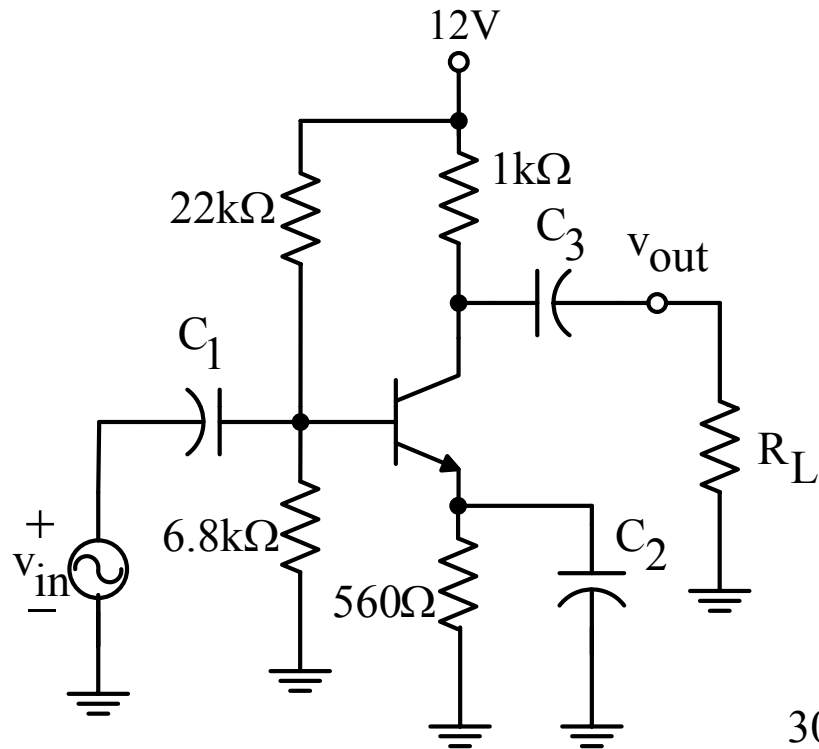

dc equivalent circuit :

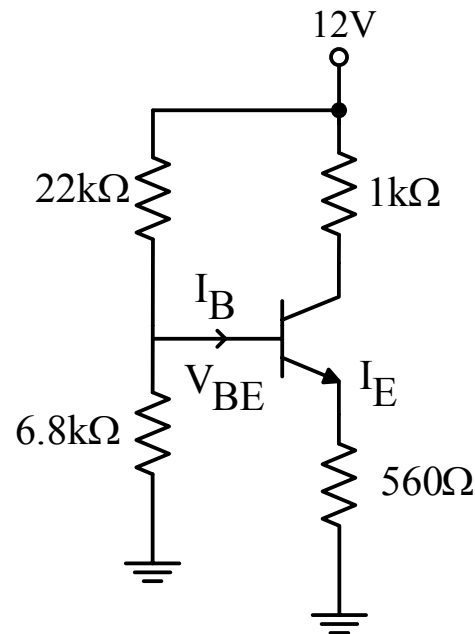

ac equivalent circuit :

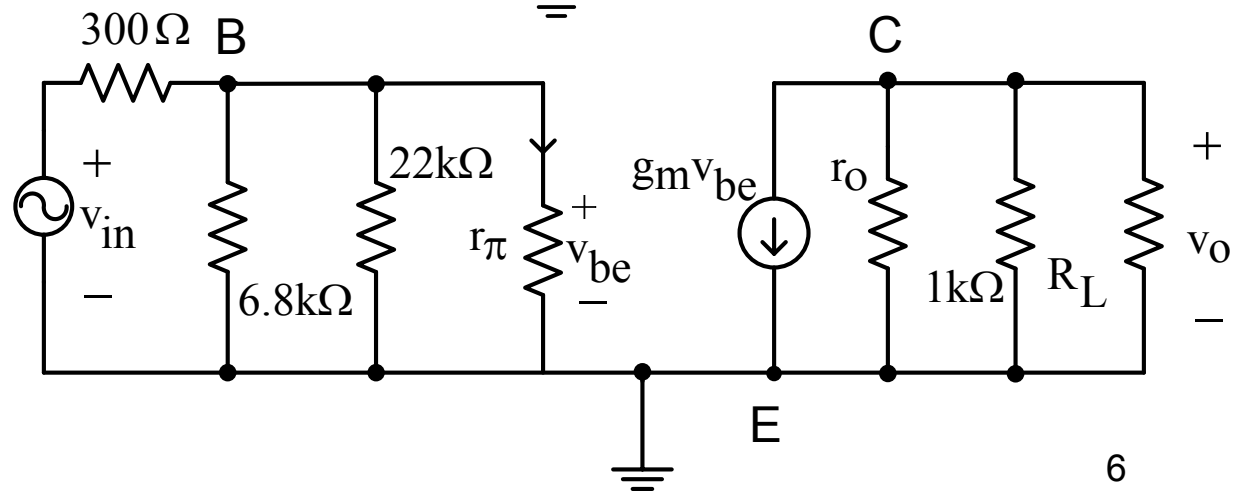

Given  $\beta_F=150$ ;  $\beta_o=160$ ;  
 $V_{BE}=0.7V$  and  $V_T=26mV$

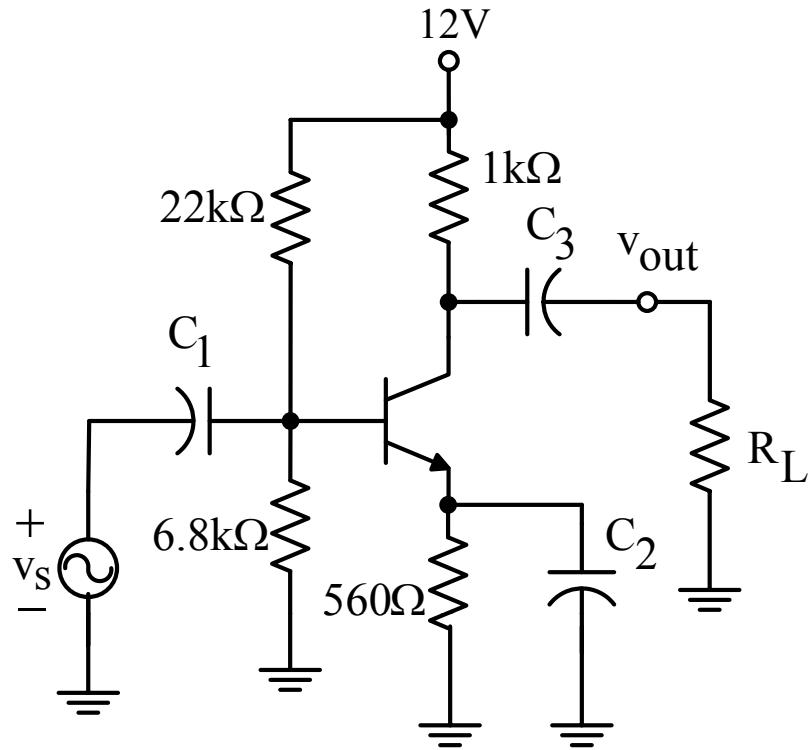

### Method 1

$$R_{IN(B)} = \frac{V_B}{I_B} = \frac{V_{BE} + I_E R_E}{I_B}$$

$$\text{Assume } V_{BE} \ll I_E R_E, R_{IN(B)} = \frac{(\beta_F + 1) I_B R_E}{I_B}$$

$$\text{where } I_E = (\beta + 1) I_B$$

$$\text{Assume } \beta_F \gg 1, R_{IN(B)} = \beta_F R_E$$

Since  $\beta_F = 150$ ,

$$R_{IN(B)} = 150(560) = 84\text{k}\Omega$$

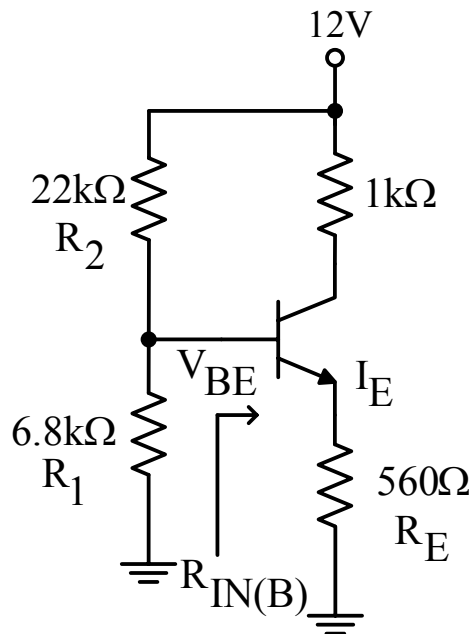

A common rule-of-thumb is that if two resistors are in parallel and one is at least ten times the other, the total resistance is taken to be approximately equal to the smaller value.

$$V_B = \frac{6.8k // R_{IN(B)}}{6.8k // R_{IN(B)} + 22k} (12) \quad \text{Since } R_{IN(B)} = 84k\Omega, V_B \approx \frac{6.8k}{6.8k + 22k} (12) = 2.8333V$$

(The exact value is  $6.8k // 84k = 6.2907k\Omega$ )

$$V_E = V_B - V_{BE} = 2.8333 - 0.7 = 2.1333V$$

$$I_E = \frac{2.1333}{560\Omega} = 3.8095mA$$

$$I_C = \alpha I_E = \frac{\beta_F}{\beta_F + 1} I_E = 3.7843mA$$

$$g_m = \frac{I_C}{V_T} = \frac{3.7843mA}{26mA} = 0.1456A/V$$

$$r_\pi = \frac{\beta_o}{g_m} = \frac{160}{0.1456} = 1098.9011\Omega$$

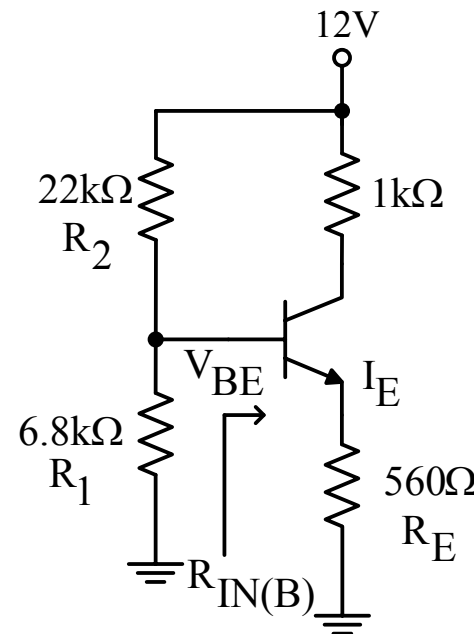



$$V_B \approx \frac{6.8k}{6.8k+22k}(12) = 2.8333V$$

$$V_E = V_B - V_{BE} = 2.1333V$$

$$I_E = 3.8095V$$

$$I_C = 3.7843mA$$

$$g_m = 0.1456A/V$$

$$r_\pi = 1098.9011\Omega$$

$$V_{be} = \frac{6.8k // 22k // r_\pi}{6.8k // 22k // r_\pi + 300} V_{in}$$

$$\frac{1}{R_T} = \frac{1}{6.8k} + \frac{1}{22k} + \frac{1}{1.0989k}$$

$$= 1.1025 \times 10^{-3}$$

$$\text{Hence, } R_T = 907.0185\Omega$$

$$v_{be} = 0.75145 v_{in}$$

$$v_{be} = 7.5145 \text{ mVrms}$$

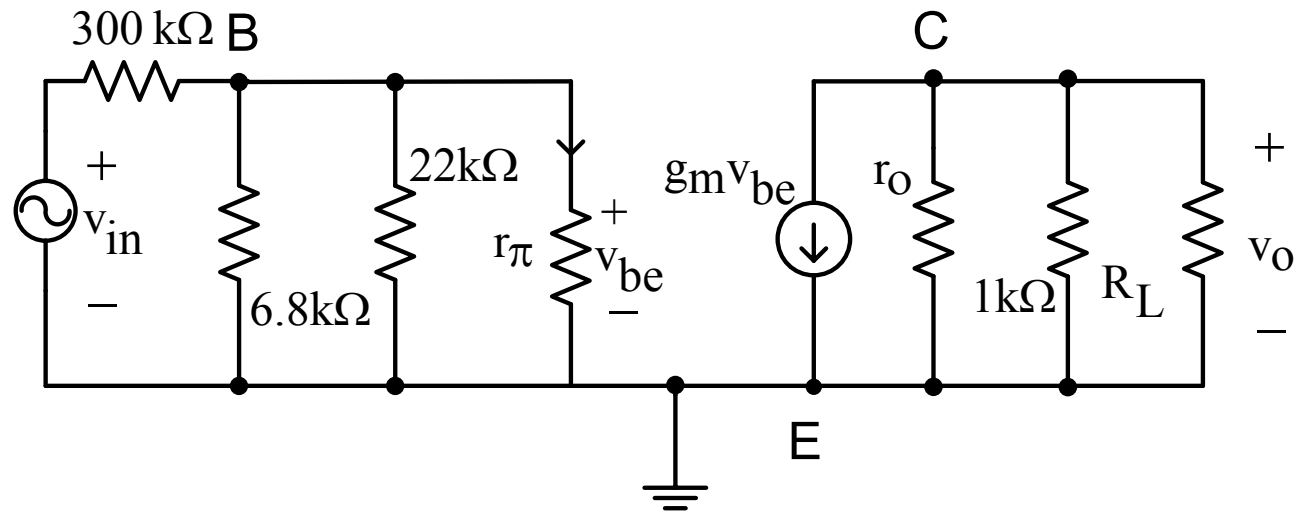

## Method 2

$$V_{TH} = \frac{6.8k}{6.8k+22k}(12) = 2.8333 \text{ V}$$

$$R_{TH} = 22k // 6.8k = 5194.4444 \Omega$$

$$-2.8333 + I_B(5194.4444) + V_{BE} + I_E(560) = 0$$

$$I_B(5194.4444 + (\beta_F + 1)560) + 0.7 = 2.8333$$

$$I_B = \frac{2.8333 - 0.7}{89754.4444} = 2.3768 \times 10^{-5} \text{ A}$$

$$V_B = 2.8333 - (5194.4444 \times 2.3768 \times 10^{-5}) = 2.7098 \text{ V}$$

$$V_E = V_B - V_{BE} = 2.0098 \text{ V}$$

$$I_E = \frac{V_E}{R_E} = 3.5889 \text{ mA}$$

$$I_C = \alpha I_E = 3.5651 \text{ mA}$$

$$g_m = \frac{I_C}{V_T} = 0.1371 \text{ A/V}$$

$$r_\pi = \frac{\beta_o}{g_m} = 1.1670 \text{ k}\Omega$$

$$V_{be} = 0.7606 \text{ V}_{in} = 7.6 \text{ mV}_{rms}$$

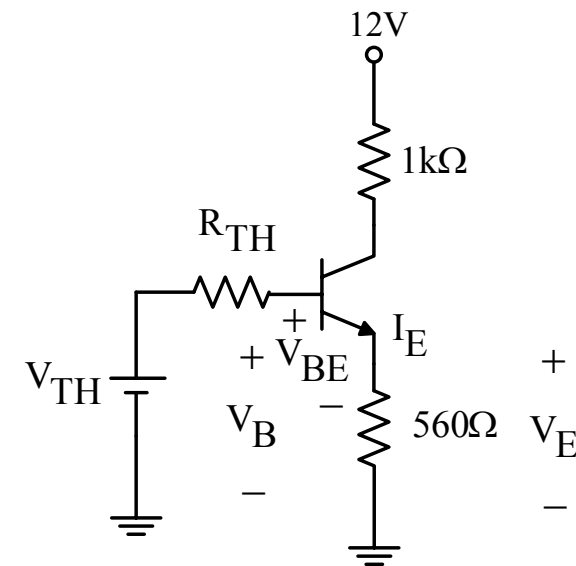
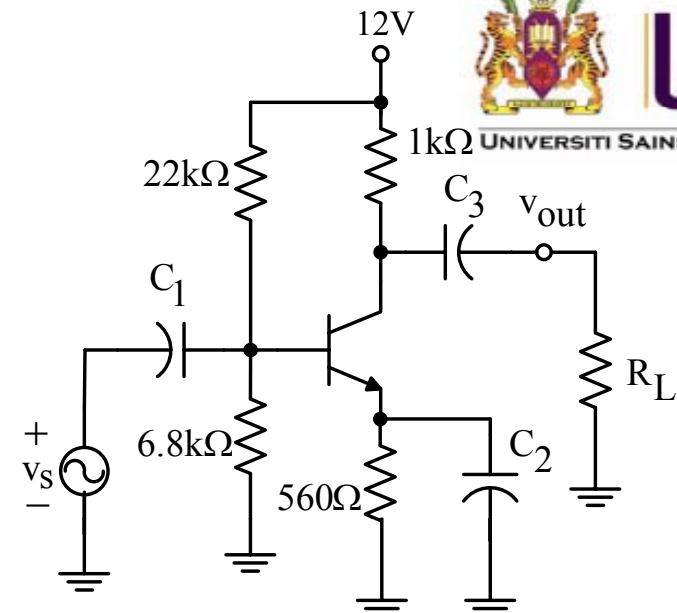

## Conclusion

Using  $V_B = \frac{R_1}{R_1 + R_2} V_{CC}$  (once it is known that  $R_{IN(B)} \geq 10 \times R_1$ )

will result in a  $\frac{V_{be}}{V_{in}}$  that is very close to the one obtained from Method 2

3. Select a minimum value for the emitter-bypass capacitor if the amplifier must operate over a frequency range from 2kHz to 10kHz

### Solution

The value of the bypass capacitor must be large enough so that its reactance over the frequency sample of the amplifier is very small (ideally  $0\Omega$ ) compared to  $R_E$ . A good rule of thumb is that  $X_C$  of the bypass capacitor should be at least 10 times smaller than  $R_E$  at the minimum frequency for which the amplifier must operate.

$$10X_C \leq R_E$$

For this circuit,  $X_C = \frac{R_E}{10} = \frac{560}{10} = 56 \Omega$

$$X_C = \frac{1}{2\pi fC}$$

$$C = \frac{1}{2\pi fX_C} = \frac{1}{2\pi(2k)56} = 1.421 \mu F$$

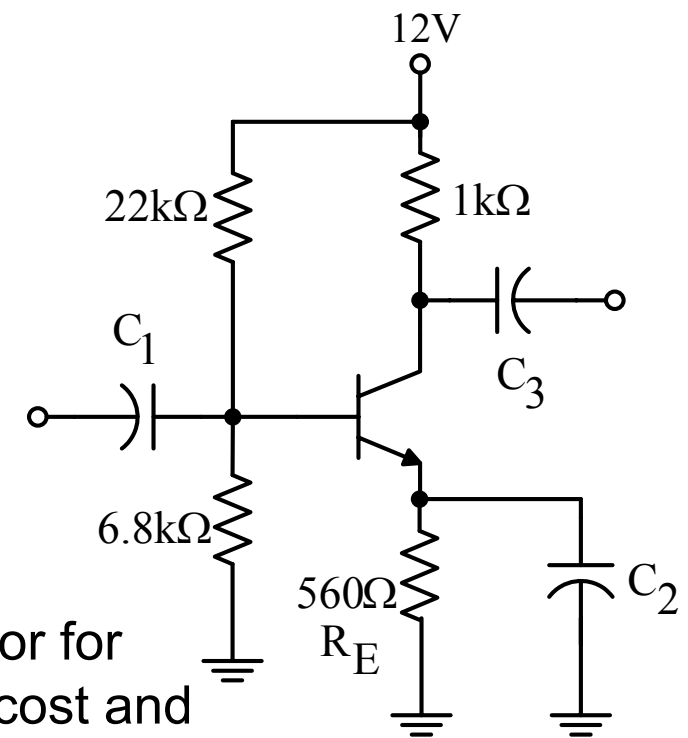

This is the minimum value for the bypass capacitor for this circuit. A larger value can be used, although cost and physical size usually impose limitations.

At the maximum frequency of 10kHz,  $X_C = \frac{1}{2\pi(10k)1.421\mu} = 11.2\Omega$



At the maximum frequency of 10kHz,  $X_C = 11.2\Omega$  and this value is  $\leq R_E / 10$  where  $R_E = 560 \Omega$

If the maximum frequency is used instead to determine C, then

$$C = \frac{1}{2\pi(10k)56} = 0.2842\mu F$$

At the minimum frequency of 2kHz,

$$X_C = \frac{1}{2\pi(2k)0.2842\mu} = 280\Omega$$

$10 X_C = 2800$  and this is  $> R_E$ . Hence, in order to calculate the minimum value of the bypass capacitor, the  $X_C$  must be 10 times smaller than  $R_E$  at the minimum frequency.

4. Calculate the voltage gain with and without the bypass capacitor.



a) With capacitor

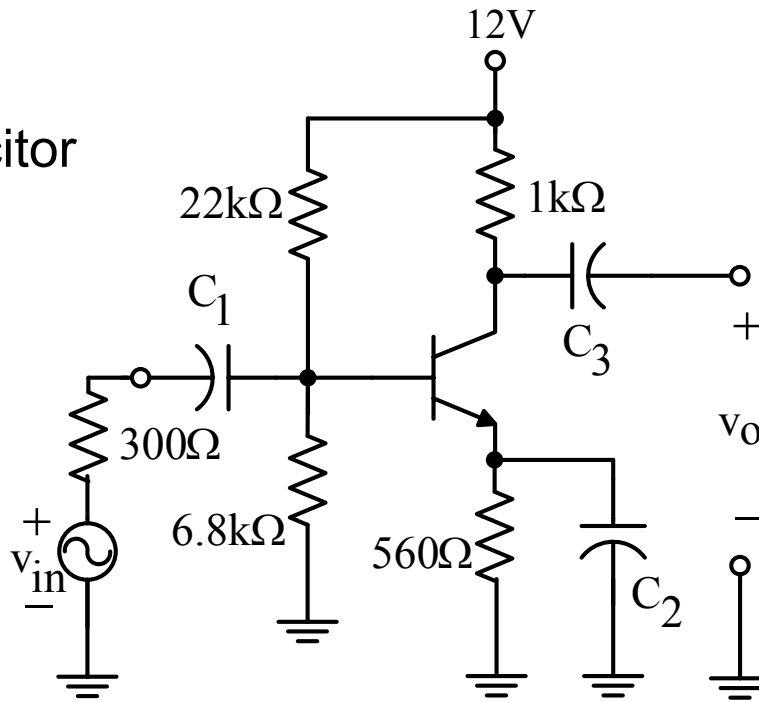

ac equivalent circuit :

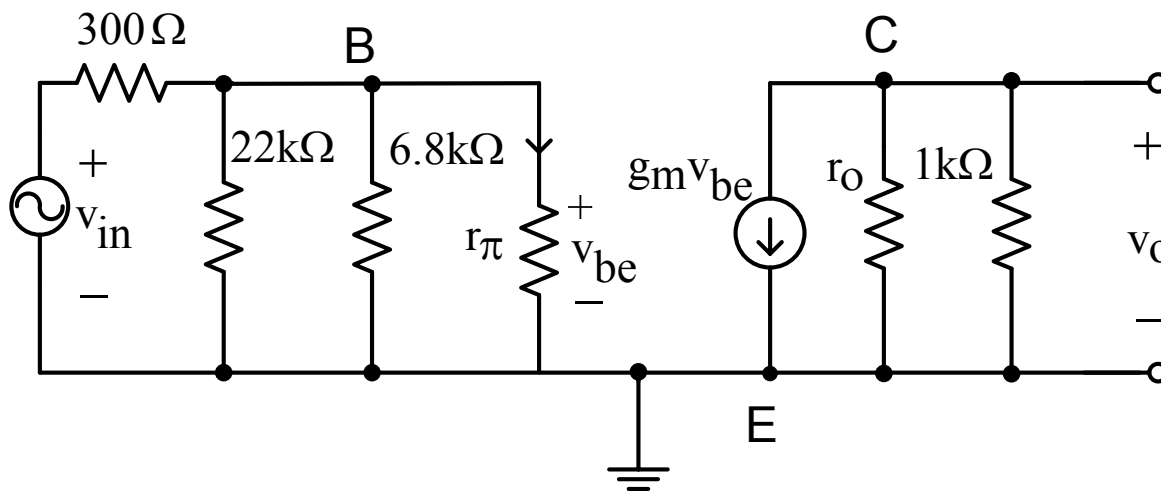

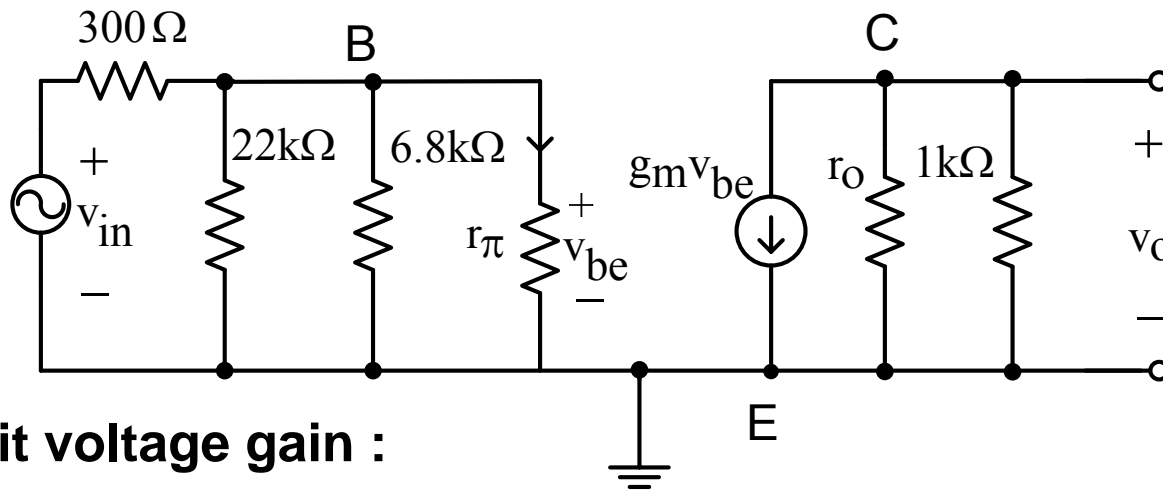

**Open circuit voltage gain :**

$$a_v = \frac{V_o}{V_{in}} = \frac{-g_m V_{be} (r_o // 1k)}{V_{in}}$$

$$\text{Assuming } r_o \gg 1k, a_v = \frac{-g_m V_{be} (1k)}{V_{in}}$$

$$\text{We know } V_{be} = \frac{22k // 6.8k // r_{\pi}}{22k // 6.8k // r_{\pi} + 300} V_{in}$$

From Question 2 (method 1),  $r_{\pi} = 1098.9011 \Omega$  and hence  $V_{be} = 0.75145 V_{in}$

$$\therefore a_v = \frac{-g_m (1k) 0.7514 V_{in}}{V_{in}}$$

From Question 2 (method 1),  $g_m = 0.1456 \text{ A/V}$

$$\therefore a_v = -109.4038$$

If there is no  $C_2$

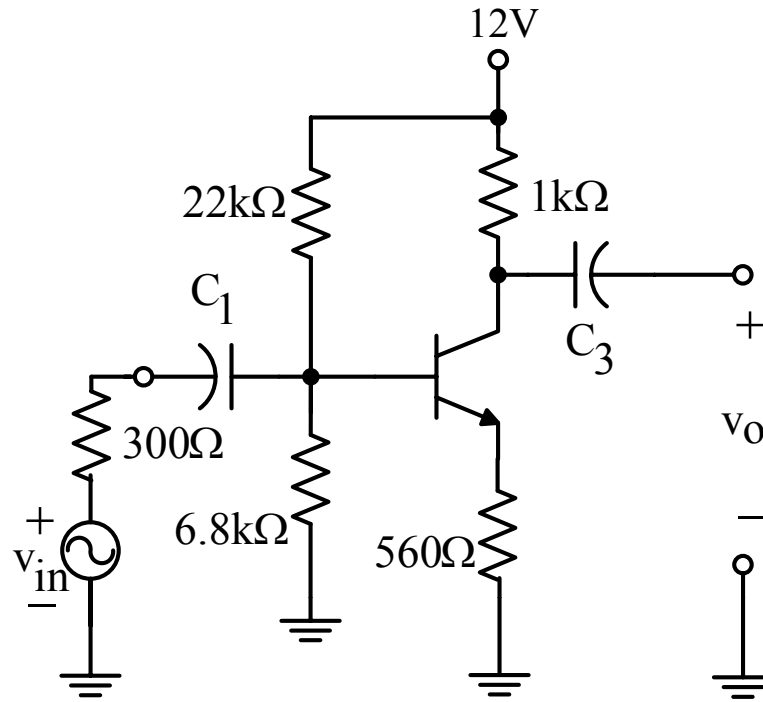

ac equivalent circuit

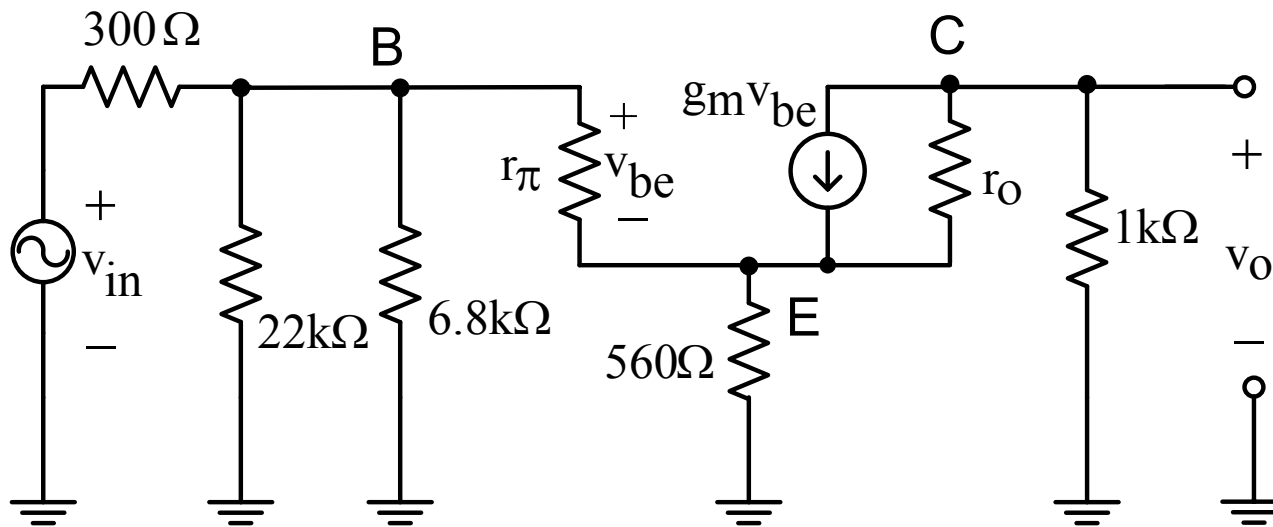



b) Without bypass capacitor :

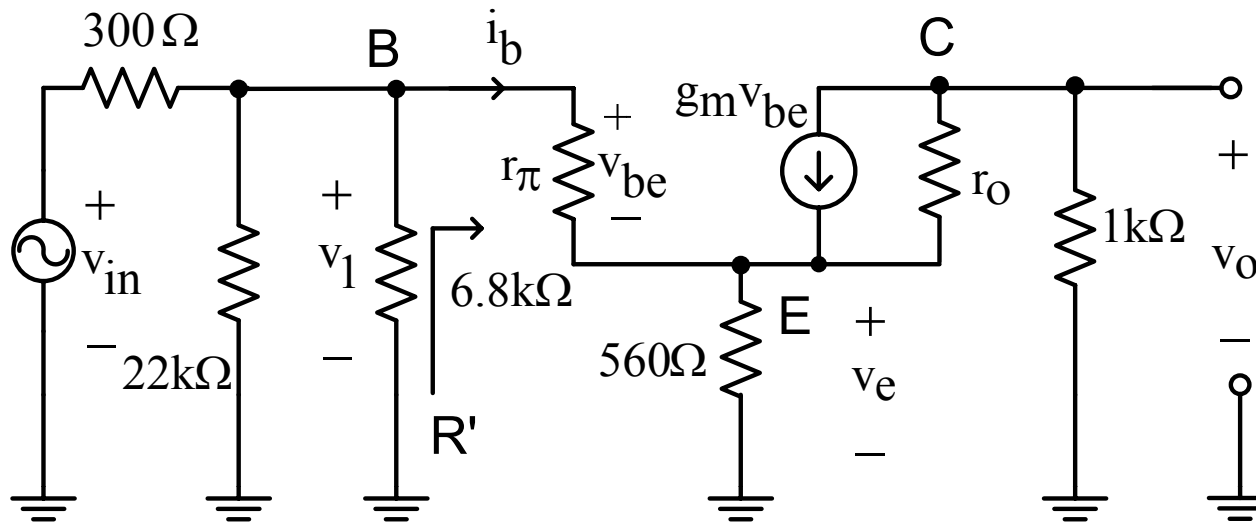

If the effect of  $r_o$  is neglected, the open circuit voltage gain :

$$a_v = \frac{v_o}{v_{in}}$$

$$v_o = -g_m v_{be} (1k)$$

$$v_1 = v_{be} + v_e$$

$$= v_{be} + (i_b + g_m v_{be}) 560$$

$$= v_{be} + v_{be} \left( \frac{1}{r_\pi} + g_m \right) 560$$

$$= \left[ 1 + \left( \frac{1}{r_\pi} + g_m \right) 560 \right] v_{be}$$

$$= \left[ 1 + \left( \frac{1}{1098.9011} + 0.1456 \right) 560 \right] v_{be}$$

$$= 83.0456 v_{be}$$

$$\Rightarrow \frac{v_o}{v_1} = \frac{-0.1456(1k)}{83.0456} = -1.7532$$

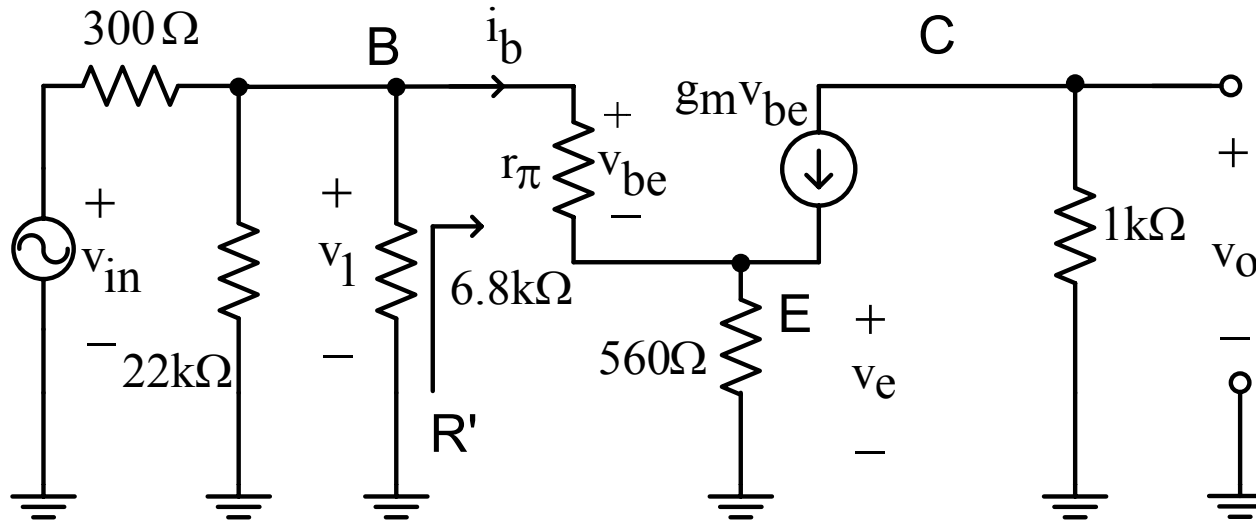

$$V_1 = \frac{(22\text{k} // 6.8\text{k} // R') v_{in}}{22\text{k} // 6.8\text{k} // R' + 300}$$

$$R' = \frac{v_1}{i_b} = \frac{83.0456 v_{be} (r_{\pi})}{v_{be}} = 91.2589\text{k}\Omega$$

$$\therefore v_1 = \frac{4914.7 v_{in}}{5214.7} = 0.9425 v_{in}$$

$$\frac{V_o}{V_{in}} = \frac{V_o}{V_1} \times \frac{V_1}{V_{in}} = -1.7532 \times 0.9425 = -1.6524$$

Hence, if there is no  $C_2$ , the open circuit voltage gain is very much reduced.

5. Connect a 5kΩ load to the CE amplifier shown below. Find the overall gain.

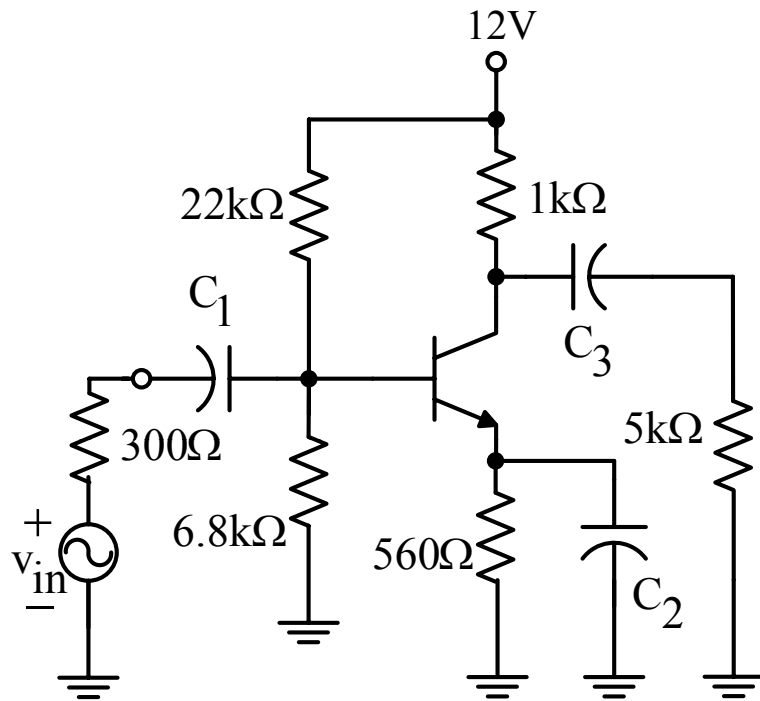

ac equivalent circuit

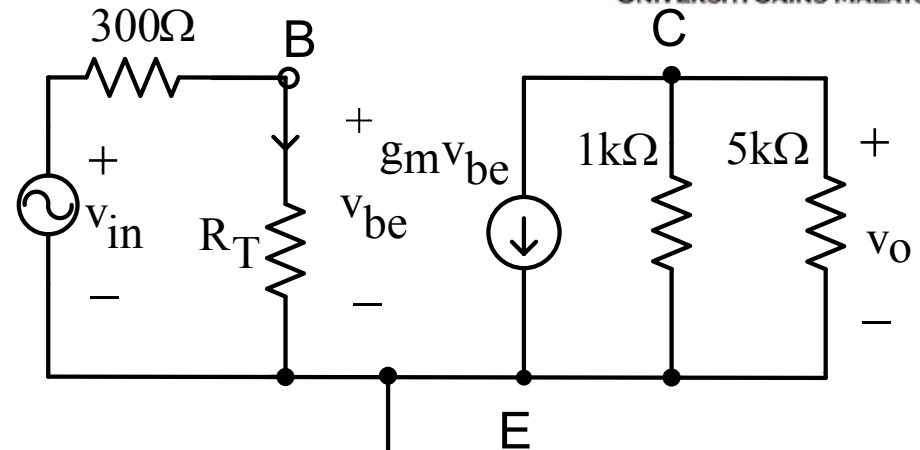

$$\begin{aligned} \therefore v_{be} &= 0.7514 v_{in} \\ \therefore a_v &= -0.1456(833.3333)(0.7514) \\ &= -91.1699 \end{aligned}$$

From Question 4, when there is no load,

$$\therefore a_v = -109.4038$$

Thus, open-circuit voltage gain is the maximum gain that can be achieved by an amplifier.

$$a_v = \frac{v_o}{v_{in}} = \frac{-g_m v_{be} (1k // 5k)}{v_{in}}$$

$$v_{be} = \frac{R_T}{R_T + 300} v_{in}$$

$$R_T = 6.8k // 22k // r_{\pi}$$

From Question 2,  $g_m = 0.1456 \text{ A/V}$ ,  $r_{\pi} = 1098.9011 \Omega$ ,  $R_T = 907.0185 \Omega$

## Conclusion



Connecting a load to the output will reduce the gain. When there is no load (i.e.  $R_L = \infty$ ), the gain of the amplifier is at its maximum. At  $R_L = \infty$ , the gain is said to be the open circuit voltage gain.

6. Find  $R_i$ ,  $a_v$ ,  $a_i$ , and  $a_p$ . Given  $\beta_F = \beta_o = 175$  and assume that the capacitances' reactances are negligible at the frequency of operation.  $V_T = 26\text{mV}$  and  $V_{BE} = 0.7\text{V}$ . Neglect  $r_o$ .

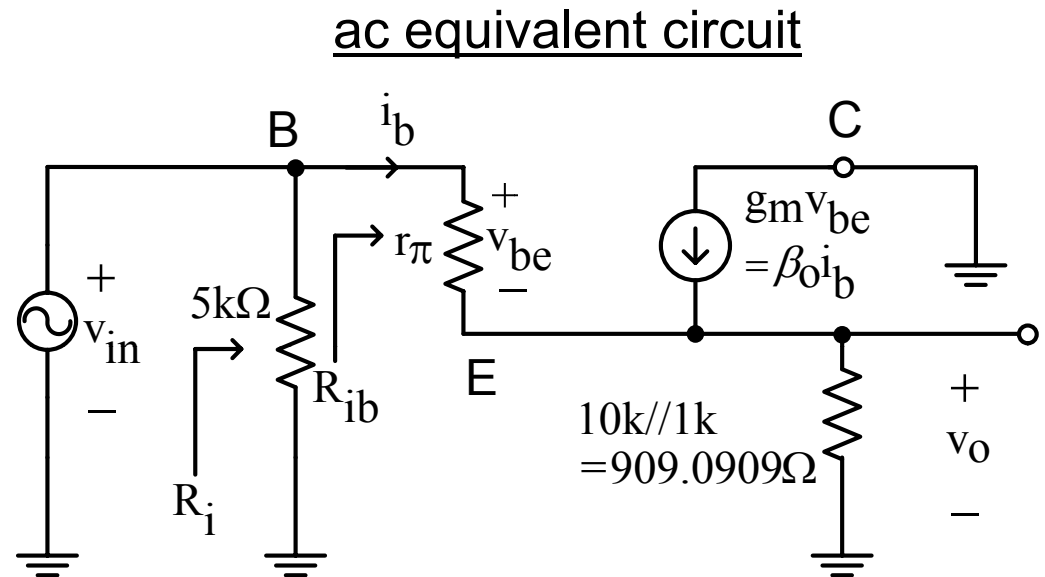
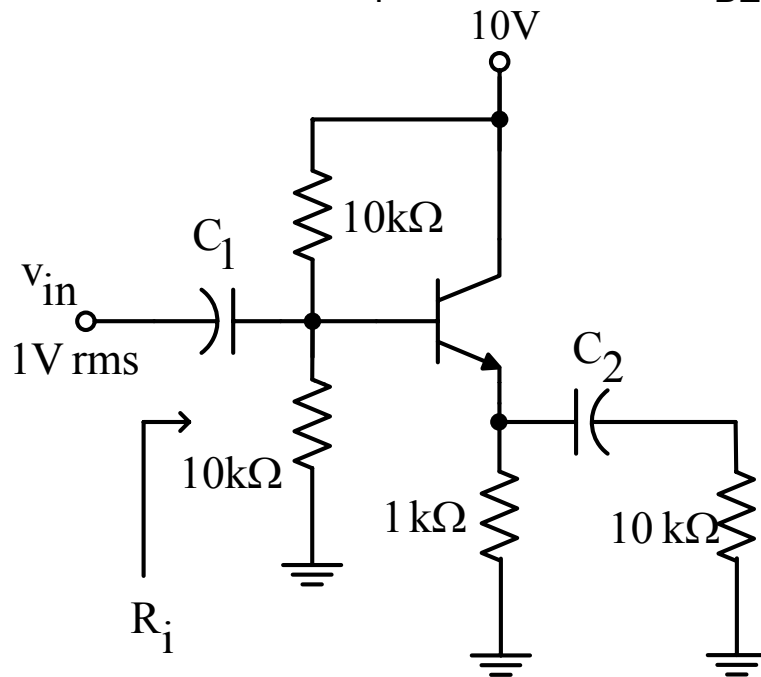

$$R_{IN(B)} = \beta_F(1k) = 175k\Omega$$

$$R_{IN(B)} \geq 10R_2$$

$$\therefore V_B = \frac{10k}{20k}(10) = 5V$$

$$\therefore V_E = V_B - 0.7 = 4.3V$$

$$I_E = \frac{4.3}{1k} = 4.3\text{mA}$$

$$I_C = \alpha I_E = \frac{175}{176}(4.3\text{mA}) = 4.2756\text{mA}$$

$$\therefore r_\pi = \frac{175}{4.2756}(26) = 1064.1781\Omega$$

$$R_{ib} = \frac{v_{in}}{i_b} = \frac{i_b r_\pi + (i_b + \beta_o i_b) 909.0909}{i_b}$$

$$\therefore R_{ib} = r_\pi + (1 + \beta_o) 909.0909$$

$$R_{ib} = 1064.1781 + (176)909.0909 = 161.0642k\Omega$$

$$R_i = 5k // 161.0642k = 4.8494k\Omega$$

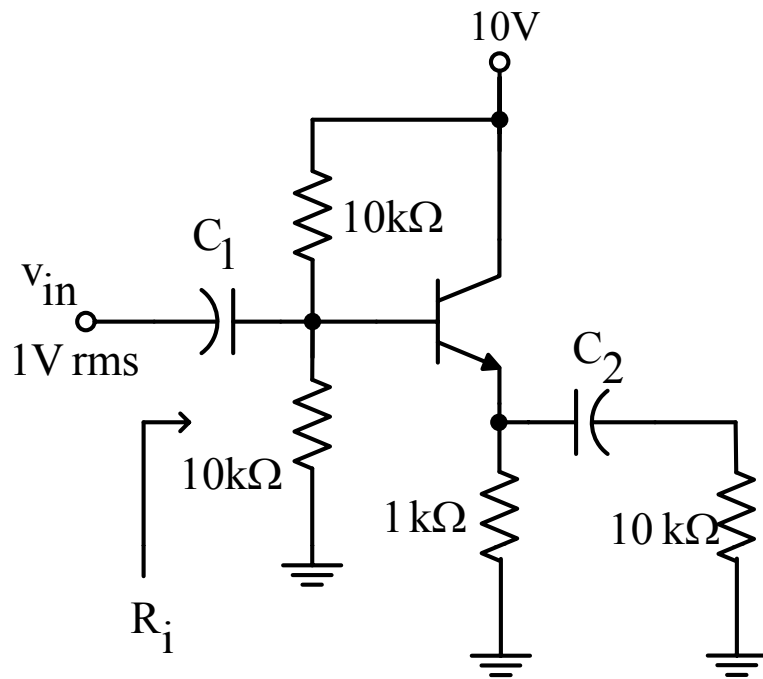

$$\begin{aligned}
 a_v = \frac{v_o}{v_{in}} &= \frac{(i_b + \beta_o i_b) 909.0909}{i_b r_\pi + (i_b + \beta_o i_b) 909.0909} \\
 &= \frac{(1 + \beta_o) 909.0909}{r_\pi + (1 + \beta_o) 909.0909} \\
 &= \frac{159999.9984}{161064.1765} \\
 &= 0.9934
 \end{aligned}$$

$$r_\pi = \frac{\beta_o}{g_m} = \frac{175}{I_C} (26\text{mV})$$

ac equivalent circuit

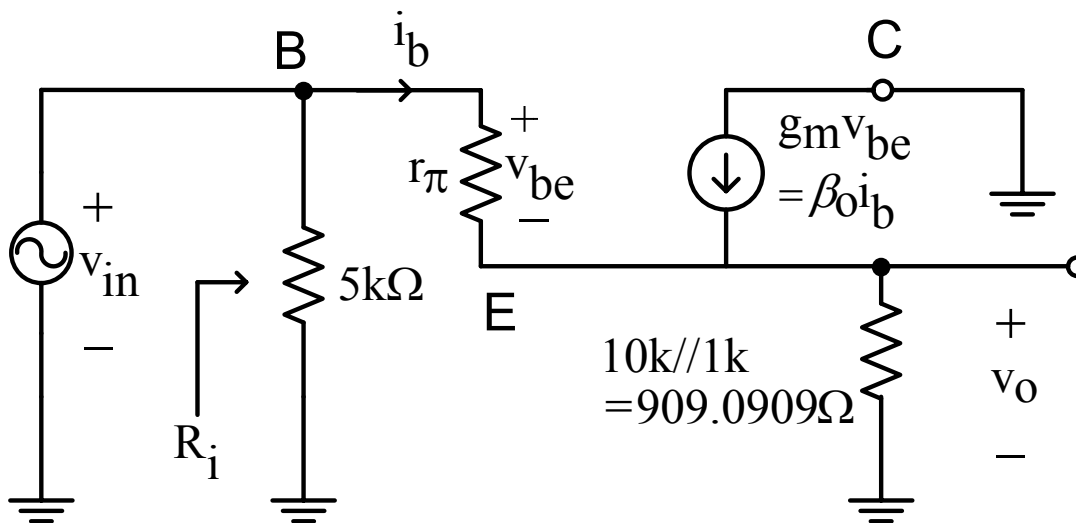

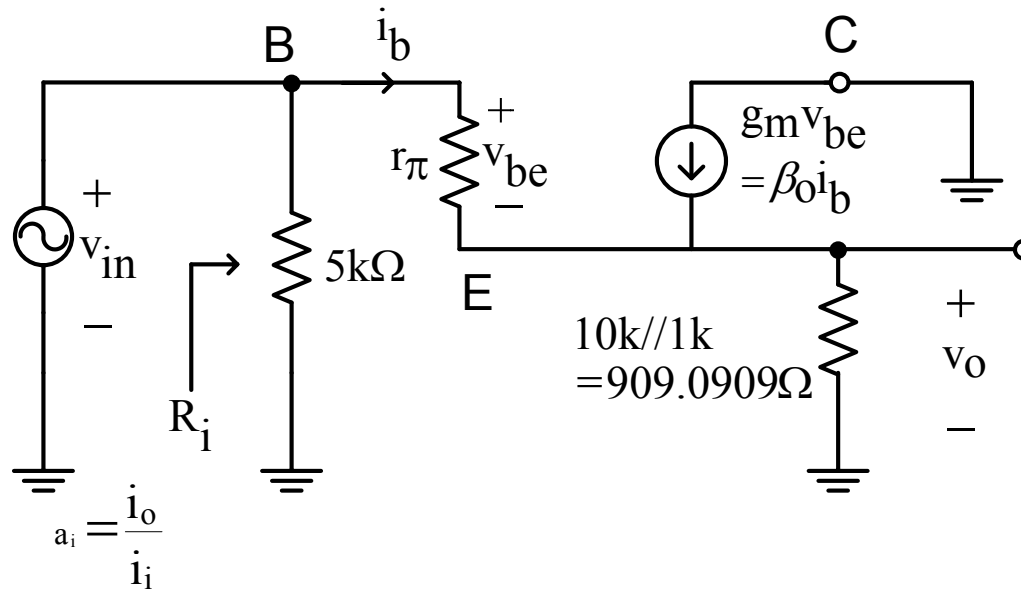

$$\begin{aligned}
 &= \frac{i_b(1+\beta_o)}{\frac{i_b r_\pi + (1+\beta_o)i_b 909.0909}{5k} + i_b} \\
 &= \frac{i_b(1+\beta_o)}{\frac{i_b r_\pi + (1+\beta_o)i_b(909.0909)}{5k} + i_b} \\
 &= \frac{176}{\frac{1064.1781 + 176(909.0909)}{5k} + 1} \\
 &= \frac{176}{33.2128} \\
 &= 5.2992
 \end{aligned}$$

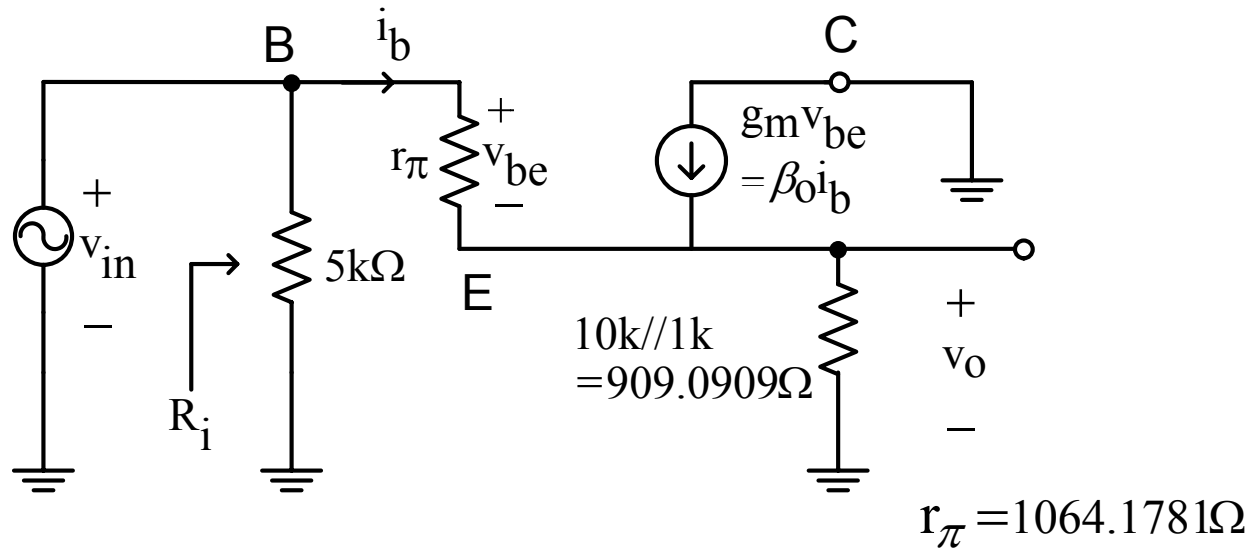

$$a_i = \frac{i_b(1+\beta_o)}{i_b r_{\pi} + (1+\beta_o)i_b(909.0909) + i_b \frac{5k}{5k}}$$

$$= \frac{176}{1064.1781 + 176(909.0909) + 1}$$

$$= \frac{176}{33.2128}$$

$$= 5.2992$$

$$a_p = a_i a_v = 5.2992 \times 0.9934 = 5.2642$$

For a CC configuration,  $a_p \approx a_i$

or

$$a_i = \frac{i_b(1+\beta_o)}{\frac{v_{in}}{R_i}}$$

$$= \frac{176}{\frac{r_{\pi} + (1+\beta_o)909.0909}{4.8494k}}$$

$$= 5.2991$$



Using Method 2 to determine  $I_C$  :

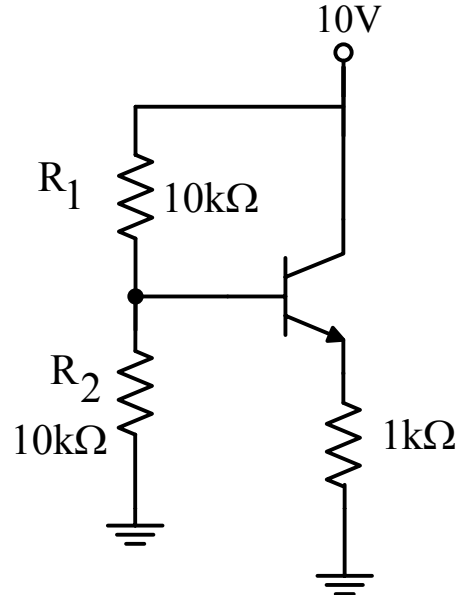

Using KVL at the input loop :

$$a_p = a_i a_v = 5.2992 \times 0.9934 = 5.2642$$

$$-5 + I_B(5k) + 0.7 + I_E(1k) = 0$$

$$I_B(5k) + I_B(1 + \beta)(1k) = 4.3$$

$$I_B = \frac{4.3}{181k} = 0.0238\text{mA}$$

$$I_C = \beta I_B = 4.165\text{mA}$$

$$r_\pi = 1092.437$$

$$R_{ib} = 1092.437 + 176(909.0909) = 161.0924k\Omega$$

$$R_i = 5k // 161.0924k = 4.8495k\Omega$$

$$a_v = \frac{176(909.0909)}{1092.437 + 176(909.0909)} = 0.9932$$

$$a_i = \frac{176(4.8495k)}{1092.437 + 176(909.0909)} = 5.2983$$

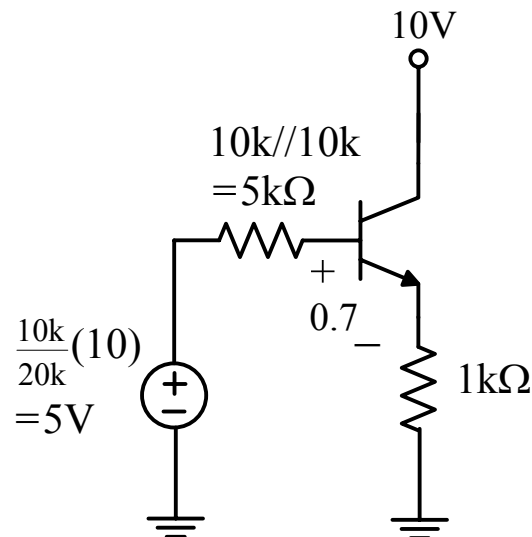

7. Given :  $\beta_F=250$ ,  $V_T=26\text{mV}$  and  $V_{BE}=0.7\text{V}$ . Find the input resistance, short circuit current gain and power gain for the amplifier shown below.

ac equivalent circuit

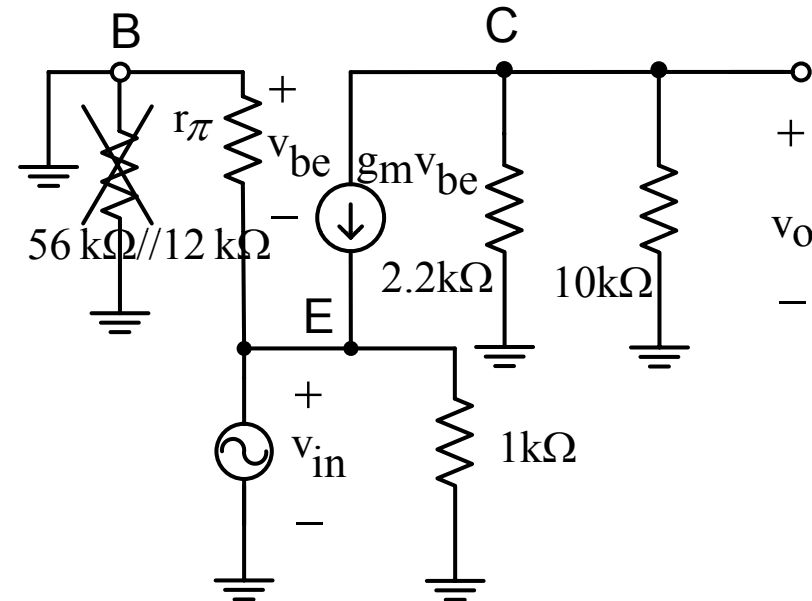
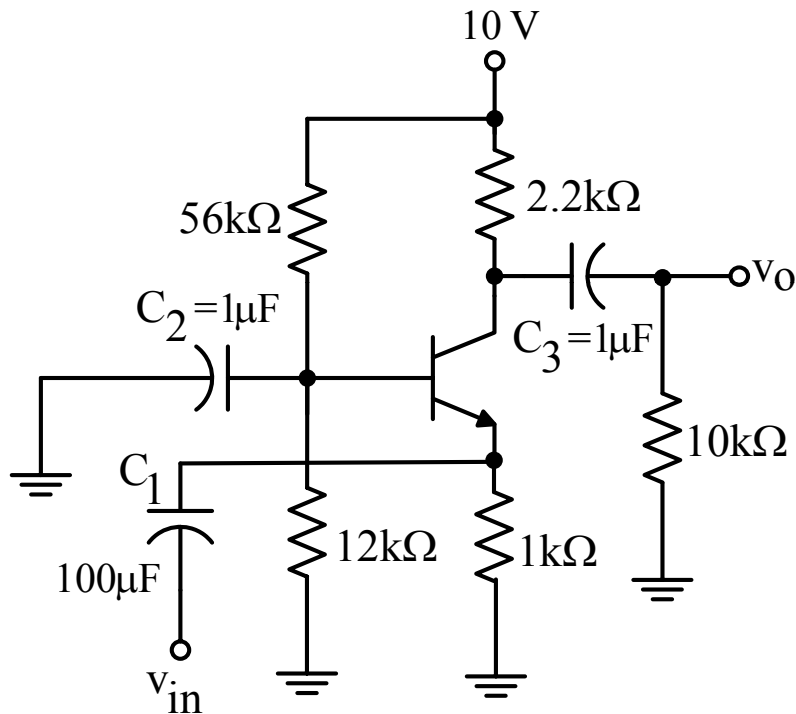

The  $56\text{ k}\Omega//12\text{ k}\Omega$  is shorted to ground and can be neglected in the small signal model. The analysis becomes difficult because the current source is between the output and the input node. Hence, use the T-model.

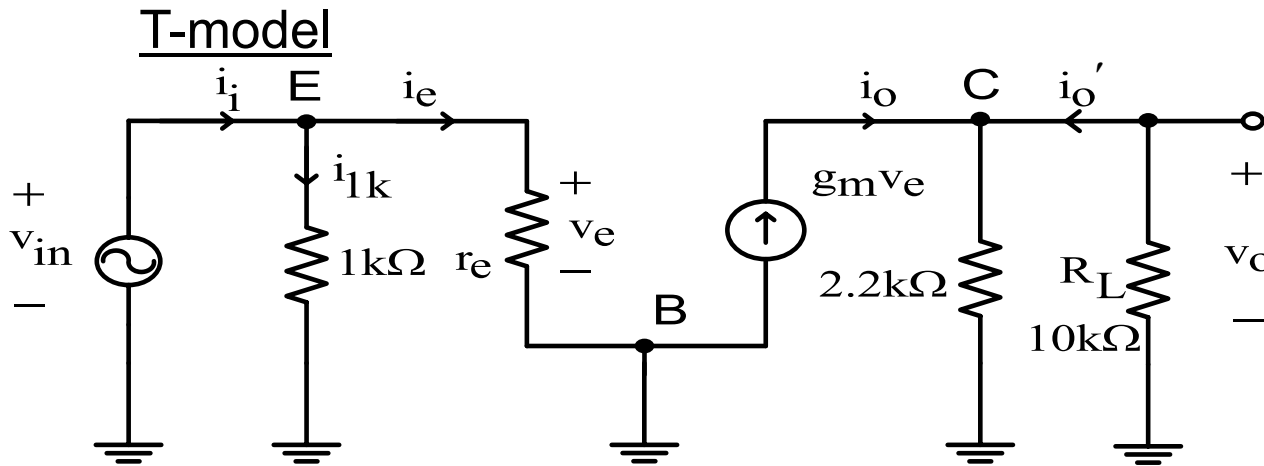

Notice that the 56 kΩ//12 kΩ are shorted to ground and can be neglected in the small signal model.

$$R_{IN(B)} = \beta_F R_E$$

$$= 250\text{k}\Omega$$

$$250\text{k} > 10 \times 12\text{k}$$

$$V_B = \frac{12\text{k}}{12\text{k} + 56\text{k}} (10)$$

$$= 1.7647$$

$$V_E = 1.7647 - 0.7$$

$$= 1.0647$$

$$I_E = 1.0647\text{mA}$$

$$I_C = 1.0604\text{mA}$$

$$R_{ie} = \frac{V_{be}}{i_e} = r_e$$

$$r_e = \frac{\alpha_o}{g_m} = \frac{1}{g_m + \frac{1}{r_\pi}}$$

$$g_m = \frac{I_C}{V_T}$$

$$I_C = 1.0604\text{mA}$$

$$\therefore g_m = 0.0408\text{A/V}$$

$$r_e = \frac{250}{251} \left( \frac{1}{0.0408} \right) = 24.4122\Omega$$

$$R_i = 1\text{k} // 24.4122 = 23.8304\Omega$$

$$R_i \approx r_e$$

$$a_v = \frac{v_o}{v_{in}}$$

$$= \frac{g_m v_e (2.2\text{k} // 10\text{k})}{v_e}$$

$$= g_m (2.2\text{k} // 10\text{k})$$

$$= 73.5738$$

$$a_{vo} = g_m (2.2\text{k})$$

$$= 89.76$$

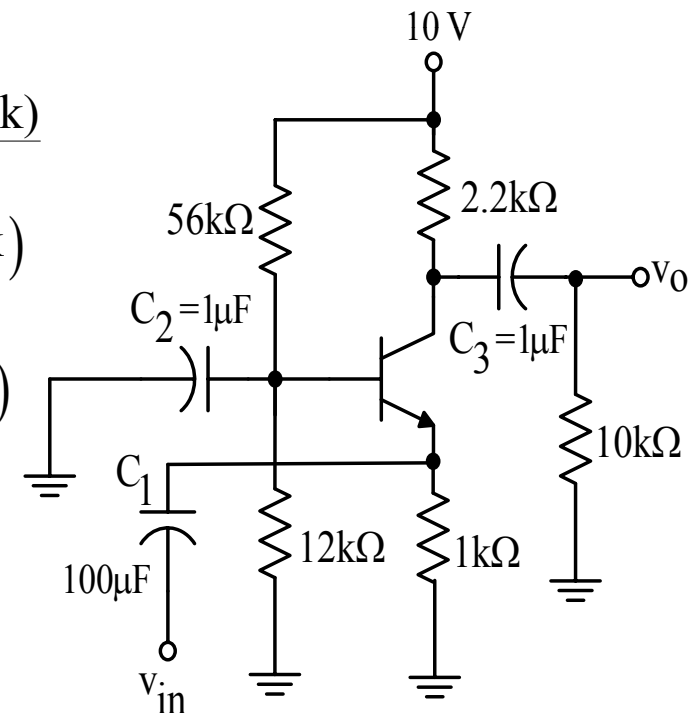

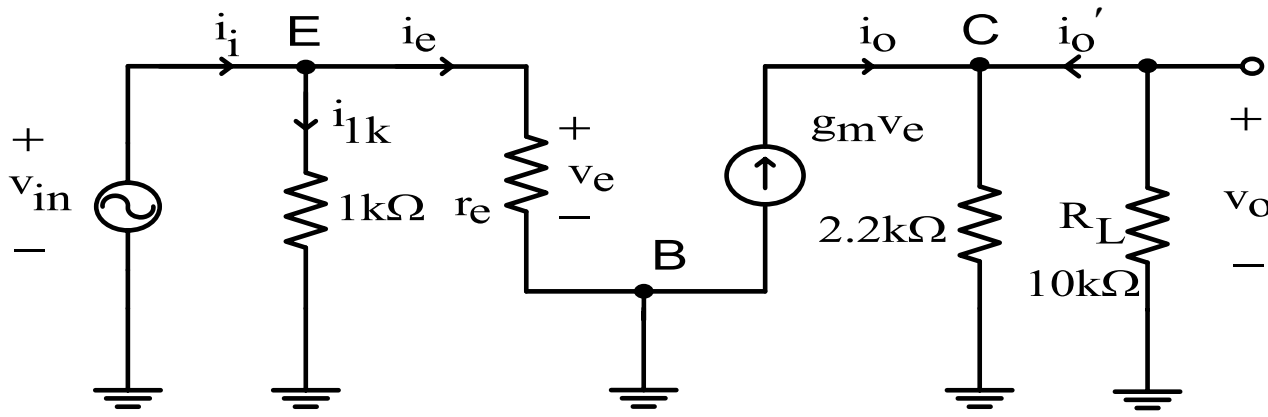

$$a_{is} = \left. \frac{i_o}{i_i} \right|_{v_o=0}$$

$$\therefore i_o = g_m v_{be}$$

$$\therefore a_{is} = \frac{g_m v_e}{v_e \left( \frac{1}{1k} + \frac{1}{r_e} \right)} = \frac{0.0408}{0.042} = 0.9714$$

KCL at node E :

$$i_i = i_e + i_{1k}$$

$$i_i = \frac{v_e}{1k} + \frac{v_e}{r_e}$$

$$i_i = v_e \left( \frac{1}{1k} + \frac{1}{r_e} \right)$$

Short-circuit current gain of a CB amplifier  $\approx 1$ .  
CB is a current buffer.

Open-circuit voltage gain,  $a_{vo} = g_m(2.2k) = 89.76$

Hence, for a CB amplifier, power gain  $\approx$  voltage gain.

$$a_p = a_{vo} a_{is} = 89.76(0.9714) = 87.1929$$

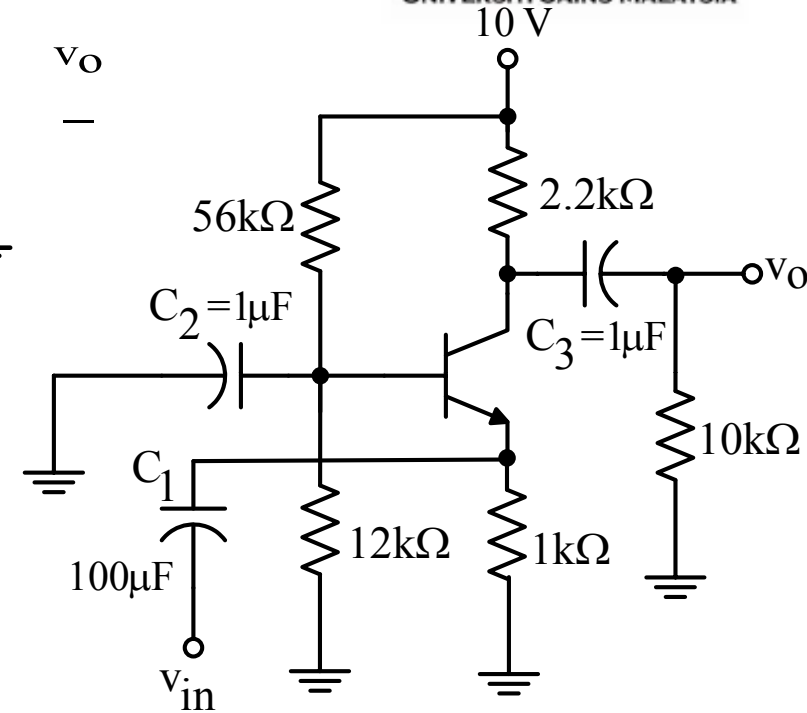

8. Given  $k = \frac{\mu_n C_{ox}}{2} \frac{W}{L} = 0.24 \times 10^{-3} \text{ A/V}^2$ ,  $V_{GSQ} = 6.4 \text{ mV}$ ,

$I_{DQ} = 2.75 \text{ mV}$  and  $r_o = 50 \text{ k}\Omega$ . Determine  $g_m$ ,  $R_i$  with and without  $r_o$  (compare the result), and  $a_v$  with and without  $r_o$  (compare the result).

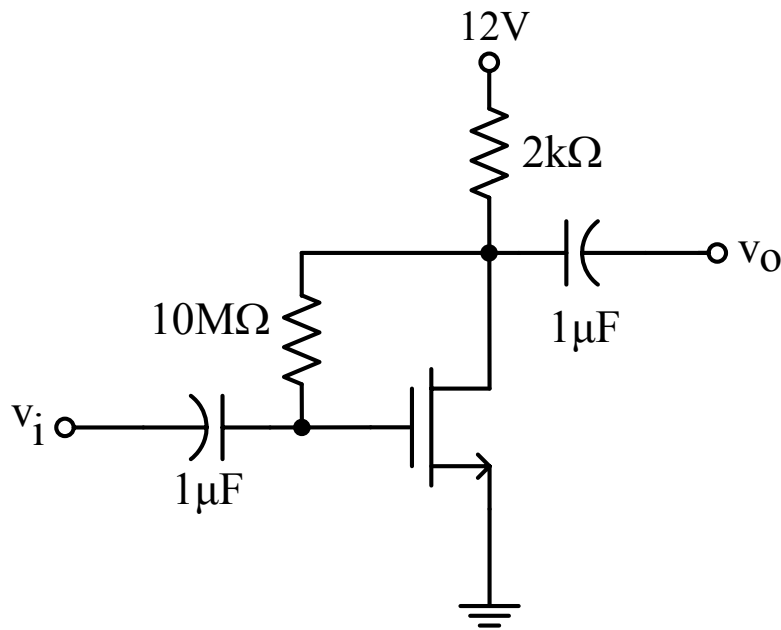

### Solution

$$g_m = \mu_n C_{ox} \frac{W}{L} (V_{GS} - V_t) = 2k(V_{GS} - V_t)$$

$$I_D = \frac{\mu_n C_{ox}}{2} \frac{W}{L} (V_{GS} - V_t)^2 = k(V_{GS} - V_t)^2$$

$$I_D = k \left( \frac{g_m}{2k} \right)^2$$

$$\therefore g_m = 2.75 \text{ m} \times 4 \times 0.24 \times 10^{-3} = 1.6248 \text{ mS}$$

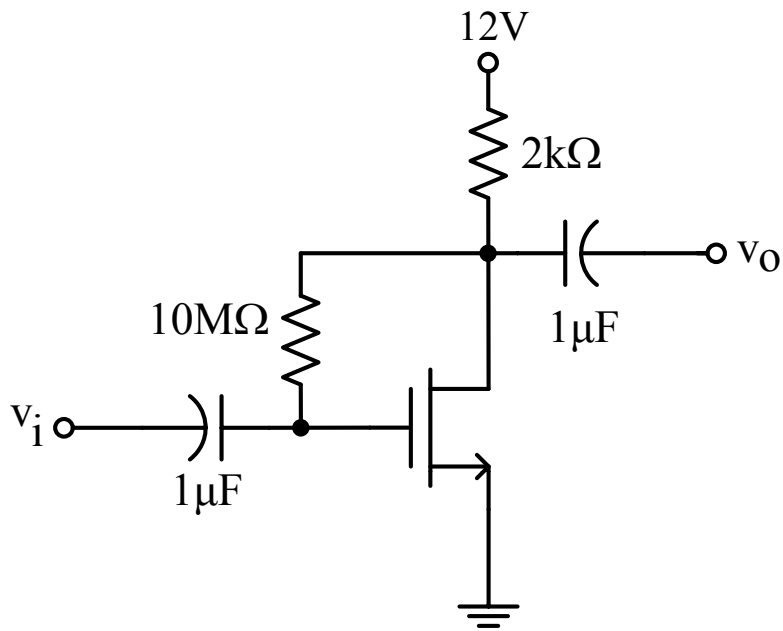

$$R_i = \frac{v_i}{i_i}$$

$$v_i = v_{gs}$$

KCL at node D :

$$i_i = g_m v_{gs} + \frac{v_o}{50k//2k}$$

$$v_o = v_{gs} - i_i(10M)$$

$$\therefore i_i = g_m v_{gs} + \frac{v_{gs} - i_i(10M)}{50k//2k}$$

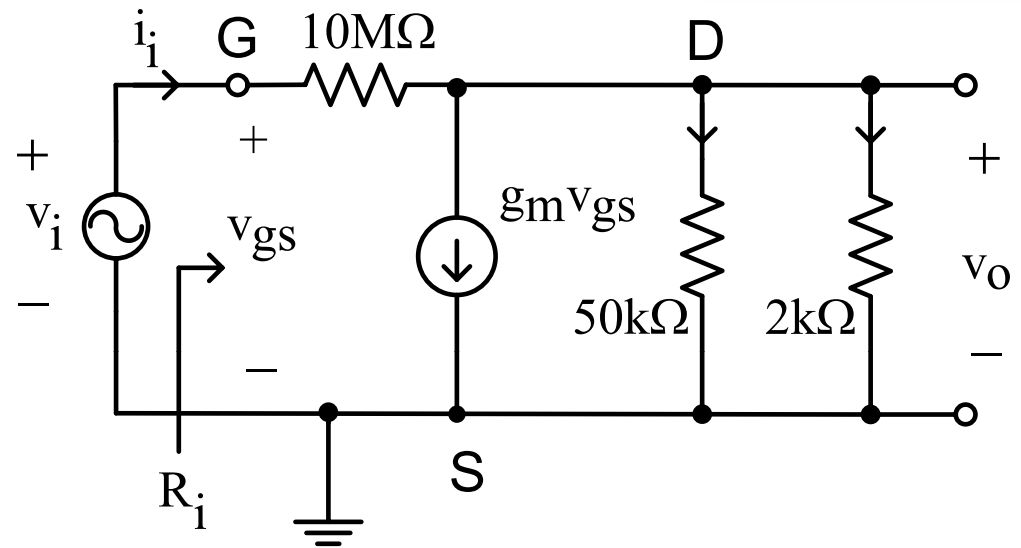

$$i_i \left( 1 + \frac{10M}{50k//2k} \right) = v_i \left( g_m + \frac{1}{50k//2k} \right)$$

$$R_i = \frac{v_i}{i_i} = \frac{\left( 1 + \frac{10M}{50k//2k} \right)}{\left( g_m + \frac{1}{50k//2k} \right)} = \frac{5201}{2.1448m} = 2.425M\Omega$$

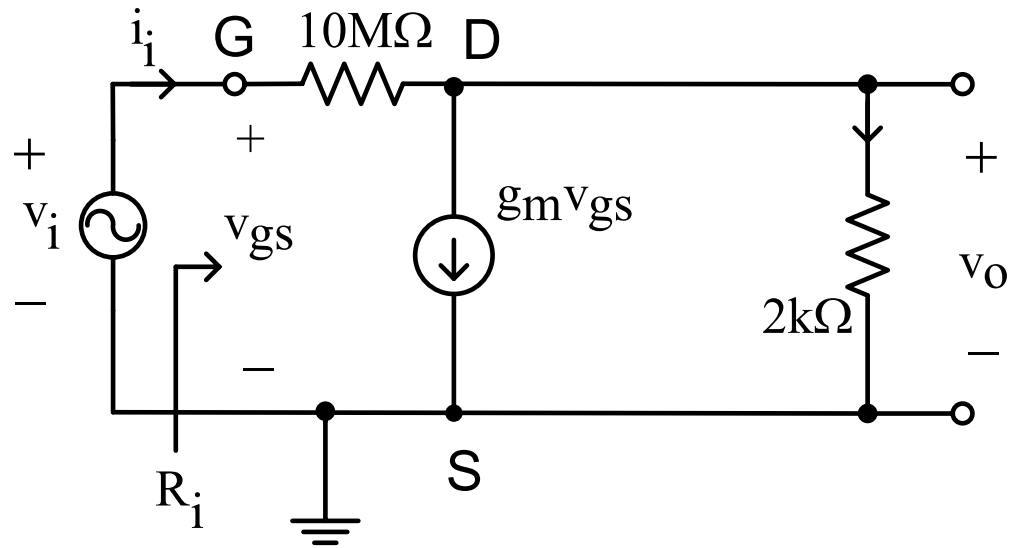

Without  $r_o$  :

$$R_i = \frac{v_i}{i_i} = \frac{1 + \frac{10M}{2k}}{g_m + \frac{1}{2k}} = \frac{5001}{2.1248m} = 2.3536M\Omega$$

Observation :

Since  $r_o > 10R_D$ ,  $R_i$  with or without  $r_o$  will be quite close.

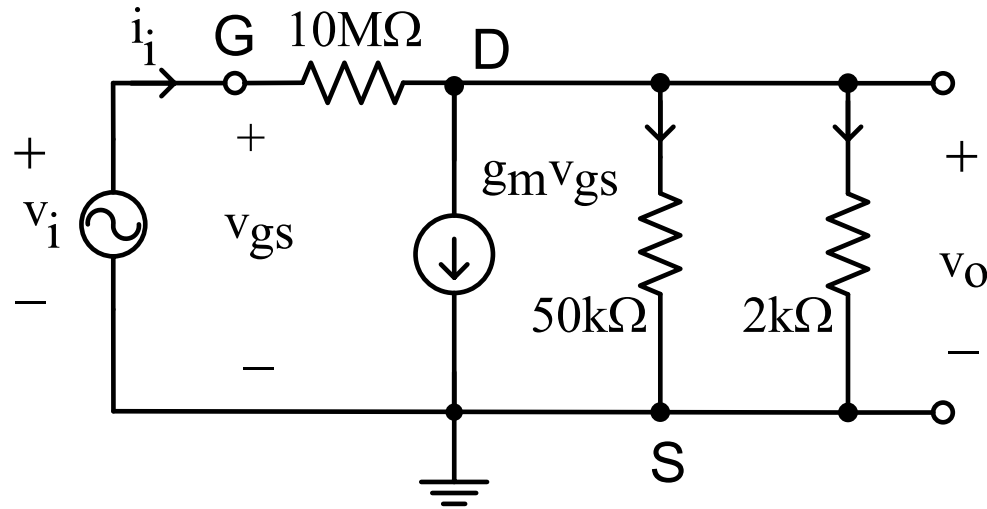

$$a_v = \frac{v_o}{v_i}$$

$$i_i = g_m v_{gs} + \frac{v_o}{50k//2k}$$

$$v_o = v_{gs} - i_i(10M)$$

$$v_o = v_i - \left( g_m v_i + \frac{v_o}{50k//2k} \right) 10M$$

$$v_o \left( 1 + \frac{10M}{50k//2k} \right) = v_i (1 - g_m(10M))$$

$$\therefore a_v = \left( \frac{1 - 1.6248m(10M)}{1 + \frac{10M}{1923.0769}} \right) = \frac{-16247}{5201} = -3.1238$$

Without  $r_o$ ,

$$\frac{v_o}{v_i} = \frac{[1 - g_m(10M)]}{1 + \frac{10M}{2k}} = \frac{-16247}{5001} = -3.2488$$

The two results are close.

Hence, the effect of  $r_o$  is not very significant to the calculation of  $a_v$ .



9. Determine the output voltage if  $V_i=0.8\text{mV}$  and  $r_o=40\text{k}\Omega$ . Given  $k=0.4\times 10^{-3}\text{ A/V}^2$  and  $V_t=3\text{V}$ . The dc voltage at source is  $1.2\text{V}$ . Assume that body effect is negligible.

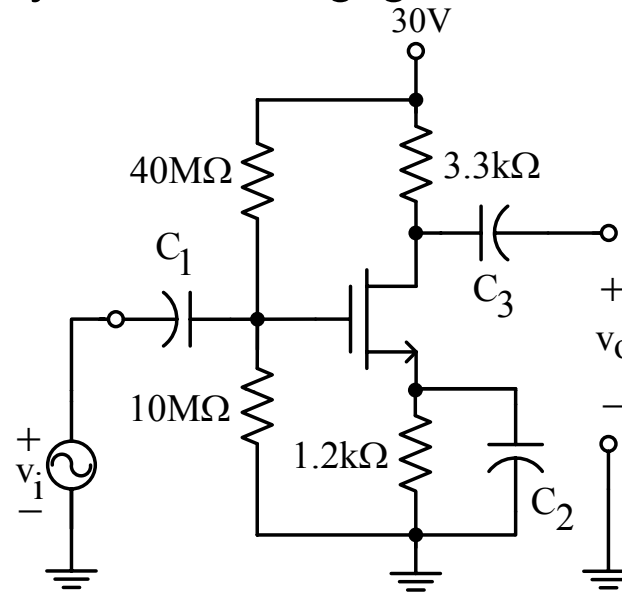

ac equivalent circuit

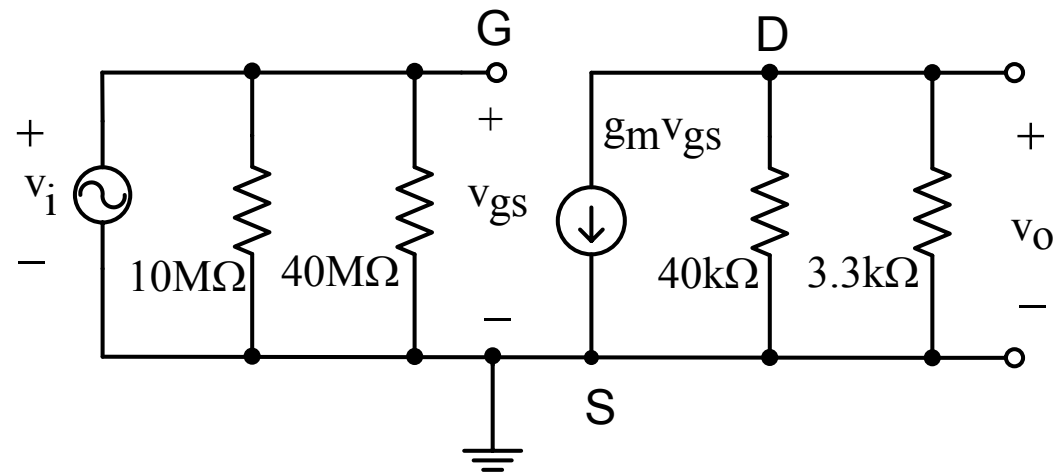

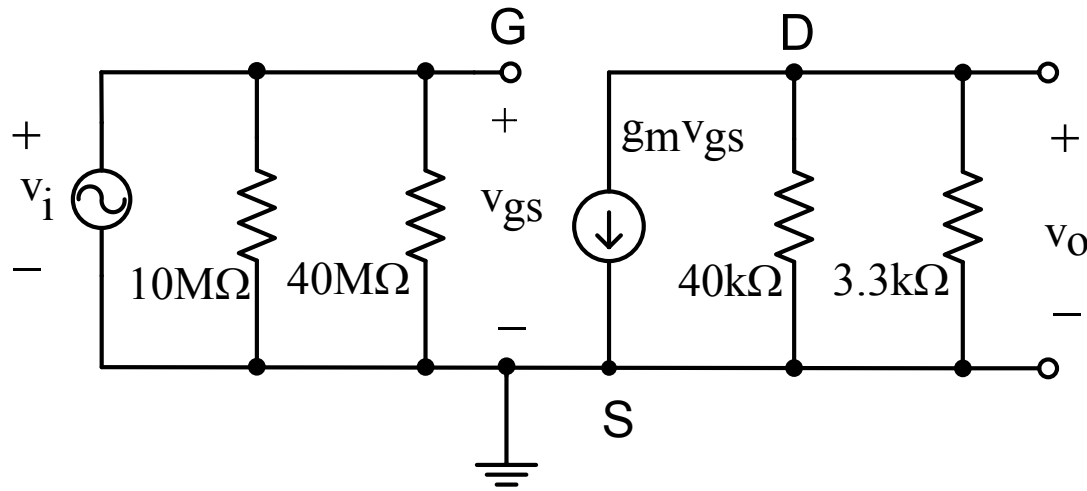

$$a_v = \frac{-g_m v_{gs} (40k // 3.3k)}{v_i}$$

$$v_i = v_{gs}$$

$$\therefore a_v = -g_m (3048.4988)$$

$$g_m = ?$$

$$g_m = \mu_n C_{ox} \frac{W}{L} (V_{GS} - V_t)$$

$$k = \frac{\mu_n C_{ox}}{2} \frac{W}{L} = 0.4 \times 10^{-3}$$

$$\therefore g_m = 0.8 \times 10^{-3} (V_{GS} - 3)$$

### dc-analysis

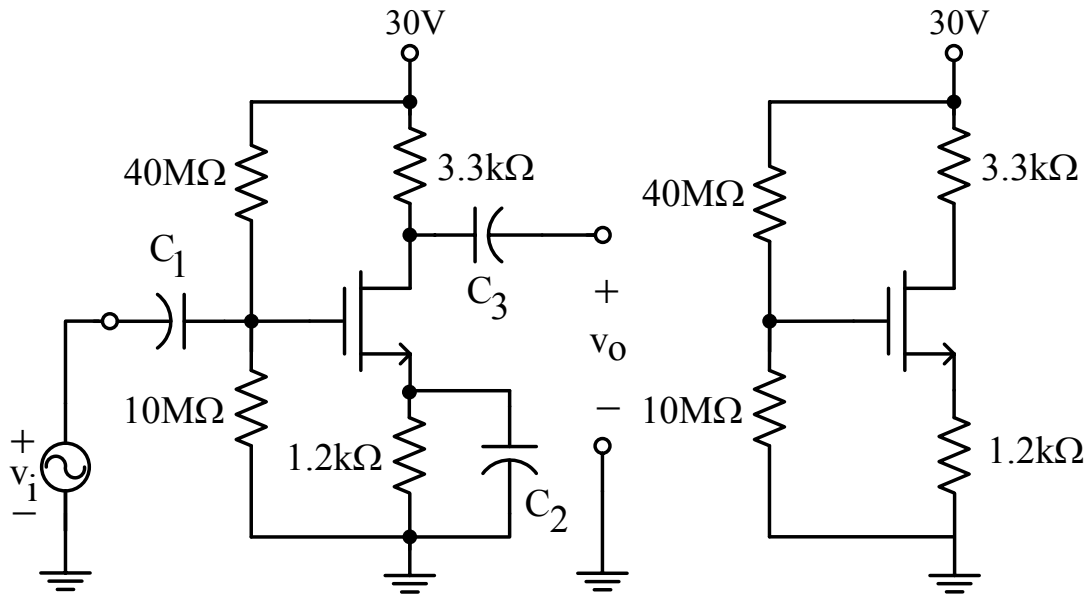

$$V_{GS} = ?$$

$$V_G = \frac{10M}{10M + 40M} (30V) = 6V$$

$$V_S = 1.2V$$

$$\therefore V_{GS} = 6 - 1.2 = 4.8V$$

$$g_m = 0.8 \times 10^{-3} (1.8) = 1.44mS$$

$$\therefore a_v = -1.44m (3048.4988) = -4.3898$$

$$v_o = a_v v_i = -4.3898 (0.8m) = -3.5118mV$$

10 (a)  $V_D = ?$   $V_{OV} = ?$   $V_{GS} = ?$   $V_G = ?$   $V_S = ?$

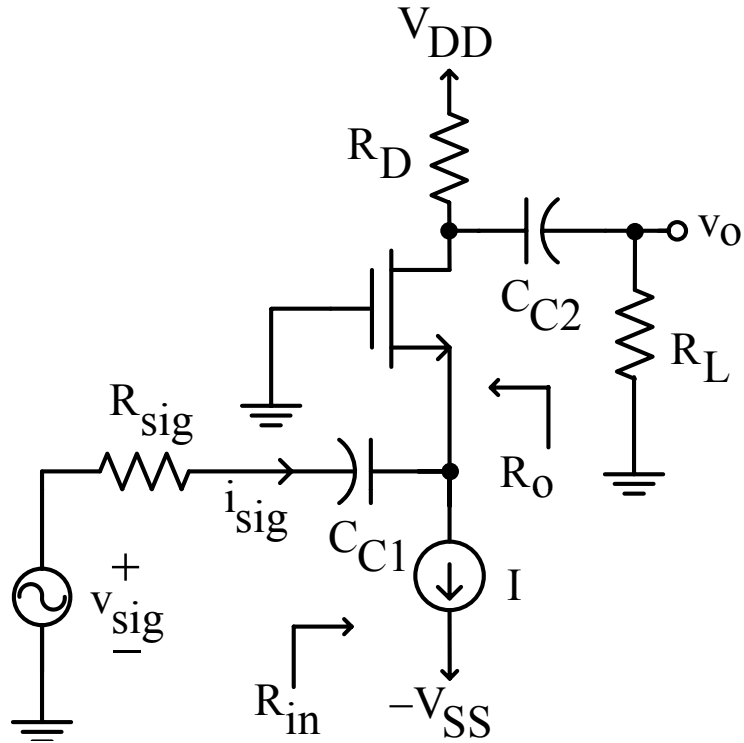

Given:

$$V_{DD} = V_{SS} = 10V$$

$$I = 0.5mA$$

$$R_D = 15k\Omega$$

$$V_t = 1.5V$$

$$\frac{\mu_n C_{ox} W}{L} = 1mA/V^2$$

$$V_A = 75V$$

DC model

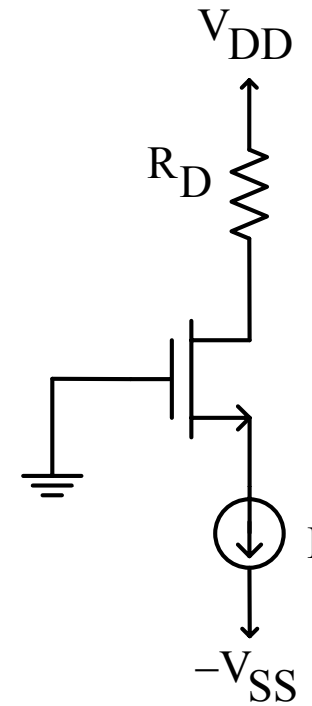

$$V_G = 0$$

$$I_D = 0.5mA$$

$$V_D = V_{DD} - I_D R_D$$

$$V_D = 10 - 0.5(15k) = 2.5V$$

$$I_D = \frac{\mu_n C_{ox}}{2} \frac{W}{L} (V_{GS} - V_t)^2$$

$$I_D = \frac{\mu_n C_{ox}}{2} \frac{W}{L} (V_{OV})^2$$

$$0.5m = \frac{1m}{2} V_{OV}^2$$

$$V_{OV} = \sqrt{\frac{(0.5m)2}{1m}} = 1V$$

$$V_{GS} - V_t = 1$$

$$V_{GS} = 1 + 1.5 = 2.5V$$

$$V_{GS} = V_G - V_S = 2.5V$$

$$\therefore V_S = -2.5V$$

(b)  $g_m = ?$   $r_o = ?$

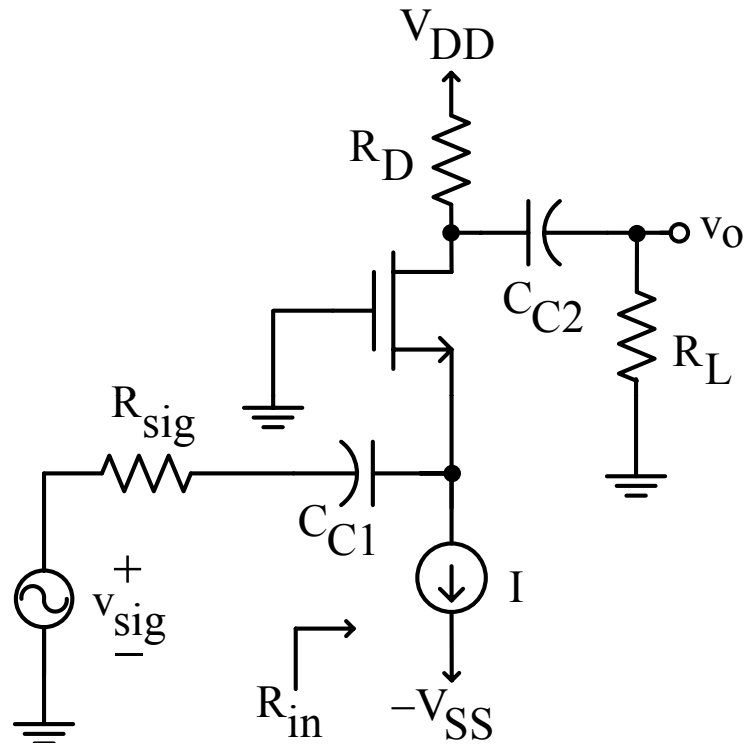

$$I_D = \frac{\mu_n C_{ox}}{2} \frac{W}{L} (V_{GS} - V_t)^2$$

$$g_m = \mu_n C_{ox} \frac{W}{L} (V_{GS} - V_t)$$

$$I_D = \frac{g_m}{2} (V_{GS} - V_t)$$

$$g_m = \frac{2I_D}{V_{GS} - V_t} = \frac{2(0.5\text{m})}{1} = 1\text{mA/V}$$

$$r_o = \frac{V_A}{I_D} = 150\text{k}\Omega$$

(c)  $R_i = ?$   $R_o = ?$   $a_v = ?$

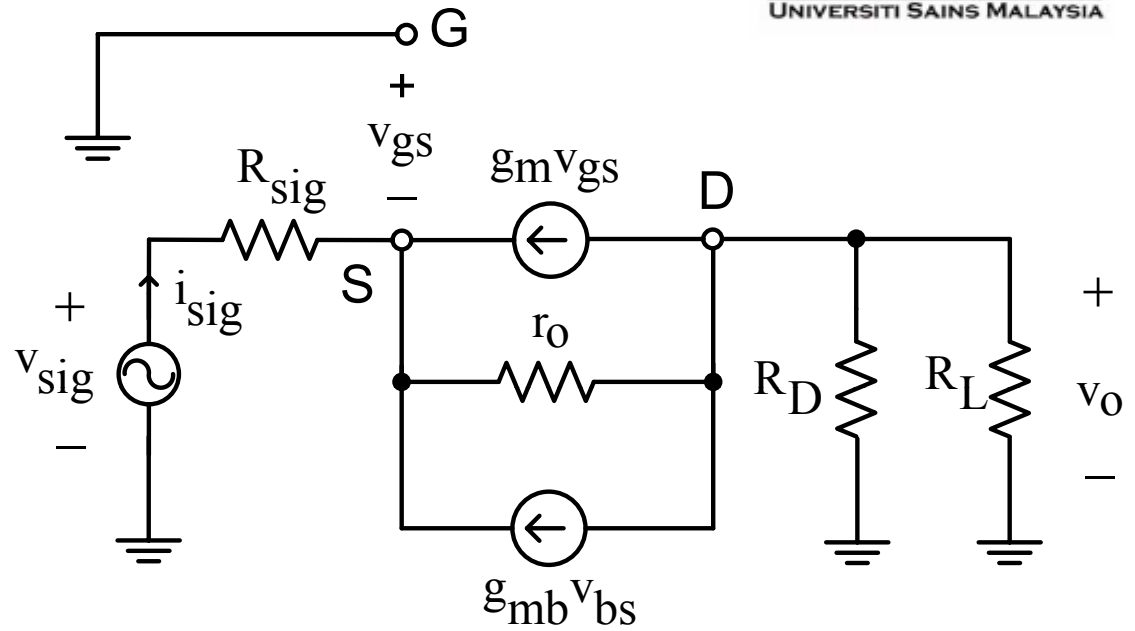
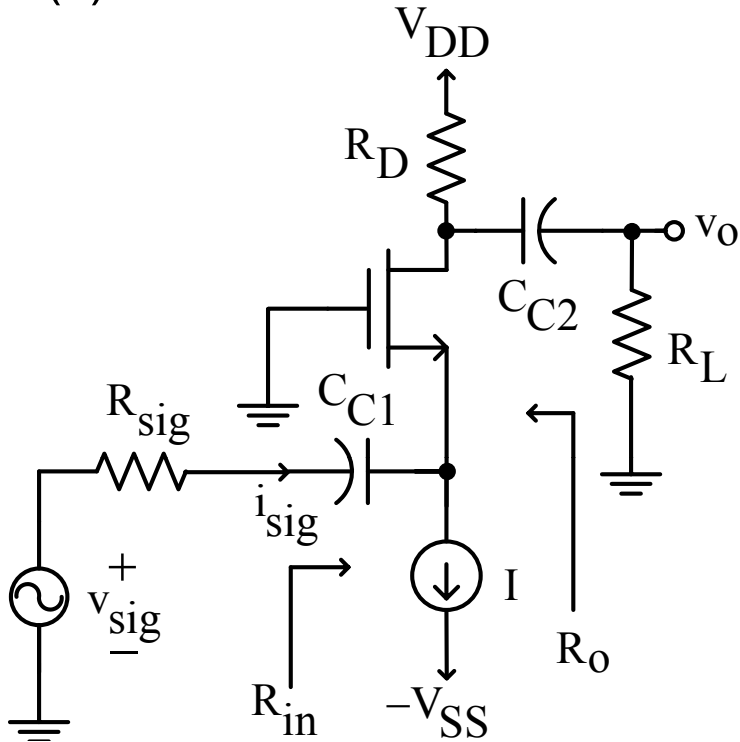

T-model

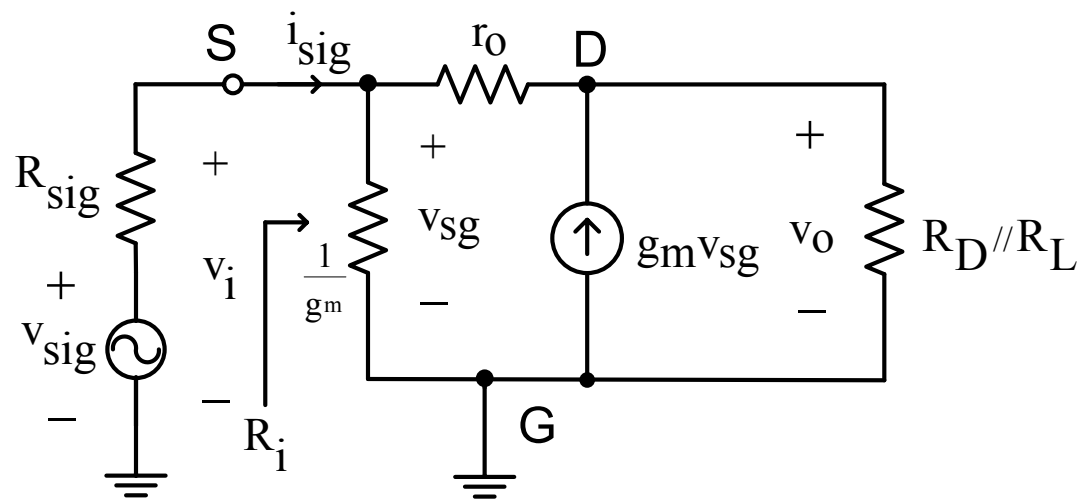

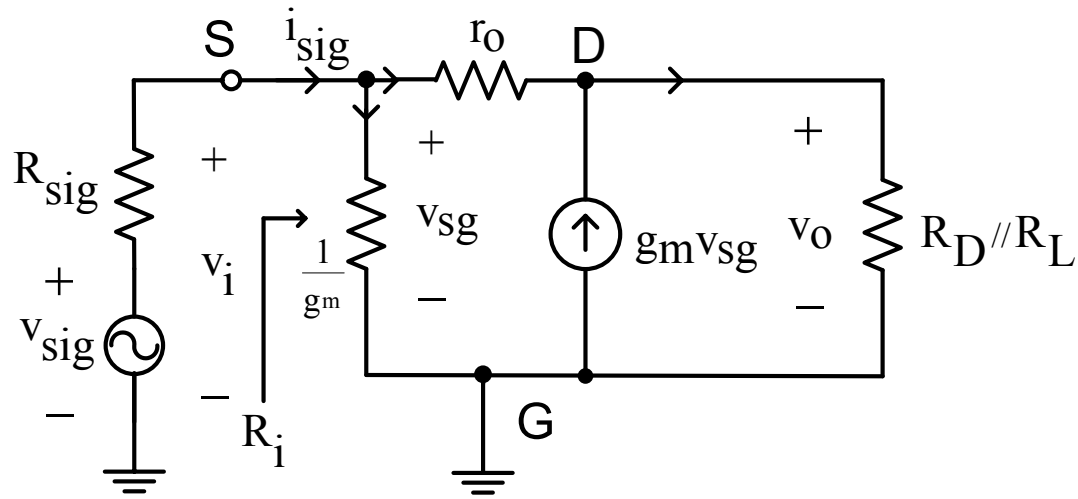

Given :

$$R_L = 15\text{k}\Omega$$

$$R_{\text{sig}} = 50\Omega$$

$$r_o = 150\text{k}\Omega$$

$$g_m = 1\text{mA/V}$$

$$R_D = 15\text{k}\Omega$$

Since  $\chi$  is not given, assume the body effect is negligible.

$$R_i = ? \quad a_v = \frac{V_o}{V_{\text{sig}}}$$

$$R_i = \frac{V_i}{i_{\text{sig}}}$$

KCL at node S,

$$V_i = V_{\text{sg}}$$

$$i_{\text{sig}} = \frac{V_i - V_o}{r_o} + g_m V_i$$

KCL at node D:

$$\frac{V_i - V_o}{r_o} + g_m V_i = \frac{V_o}{R_D // R_L}$$

$$V_i \left( \frac{1}{r_o} + g_m \right) = V_o \left( \frac{1}{r_o} + \frac{1}{R_D // R_L} \right)$$

$$V_i = V_o \frac{\left( \frac{1}{r_o} + \frac{1}{R_D // R_L} \right)}{\left( \frac{1}{r_o} + g_m \right)}$$

$$\therefore R_i = \frac{V_o r_o \left( \frac{1}{r_o} + \frac{1}{R_D // R_L} \right)}{\left( V_i - V_o + g_m r_o V_i \right) \left( \frac{1}{r_o} + g_m \right)}$$

$$R_i = \frac{V_o r_o \left( \frac{1}{r_o} + \frac{1}{R_D // R_L} \right)}{\left[ V_i (1 + g_m r_o) - V_o \right] \left( \frac{1}{r_o} + g_m \right)}$$

$$R_i = \frac{V_o r_o \left( \frac{1}{r_o} + \frac{1}{R_D // R_L} \right)}{\left[ \frac{V_o \left( \frac{1}{r_o} + \frac{1}{R_D // R_L} \right) (1 + g_m r_o)}{\left( \frac{1}{r_o} + g_m \right)} - V_o \right] \left( \frac{1}{r_o} + g_m \right)}$$

$$R_i = \frac{150k \left( \frac{1}{150k} + \frac{1}{7500} \right)}{\left[ \frac{\left( \frac{1}{150k} + \frac{1}{7500} \right) (151)}{\left( \frac{1}{150k} + 1m \right)} - 1 \right] \left( \frac{1}{150k} + 1m \right)}$$

$$R_i = \frac{21}{0.0211 - 1.0067 \times 10^{-3}}$$

$$R_i = 1045.1245 \Omega$$

$$R_D // R_L = 7.5k\Omega$$

$$r_o = 150k\Omega$$

$$g_m = 1mA/V$$

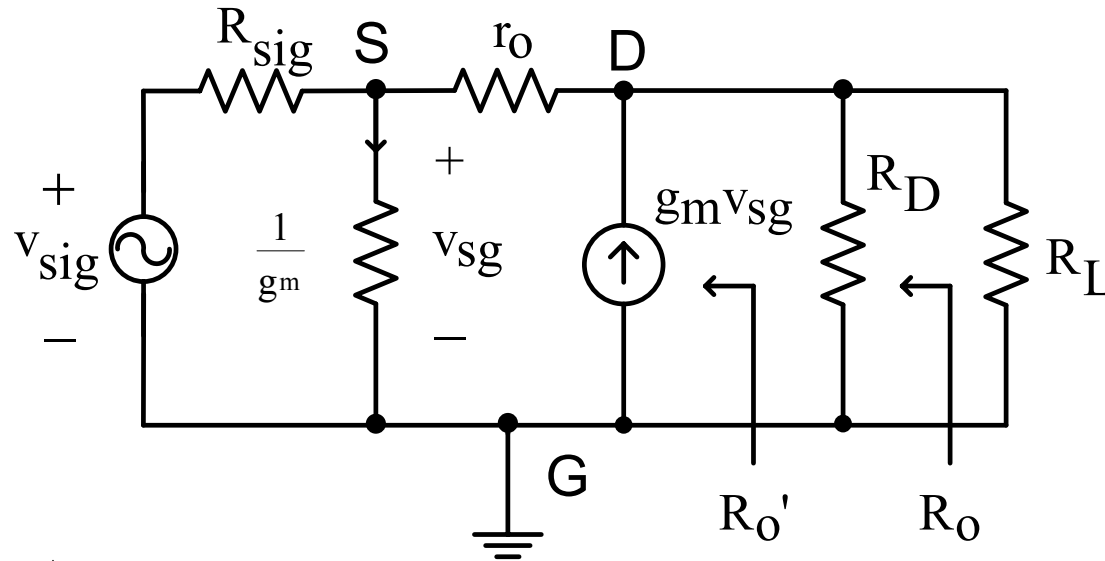

$$R_{O'} = \left. \frac{V_t}{i_t} \right|_{v_{sig}=0}$$

KCL at node S :

$$\frac{V_{sg}}{R_{sig}} + g_m V_{sg} = \frac{V_t - V_{sg}}{r_o}$$

$$V_{sg} \left( \frac{1}{R_{sig}} + g_m + \frac{1}{r_o} \right) = \frac{V_t}{r_o}$$

$$V_{sg} = \frac{V_t}{\left( \frac{1}{R_{sig}} + g_m + \frac{1}{r_o} \right) r_o}$$

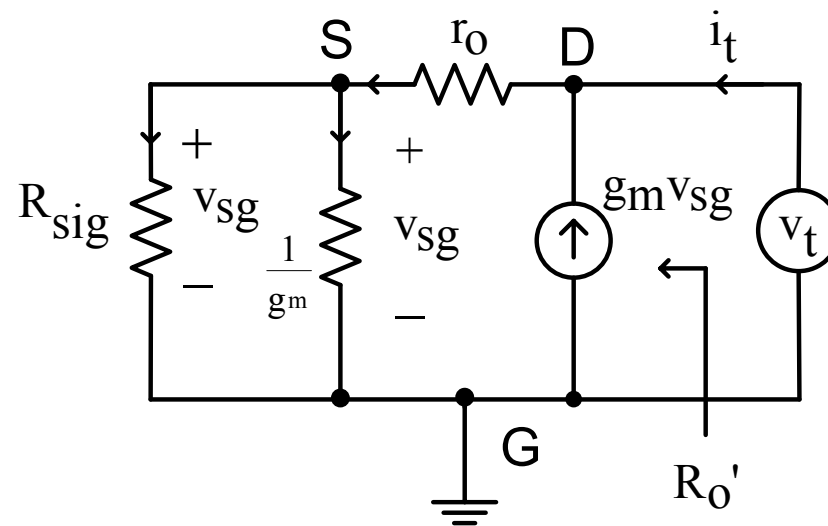



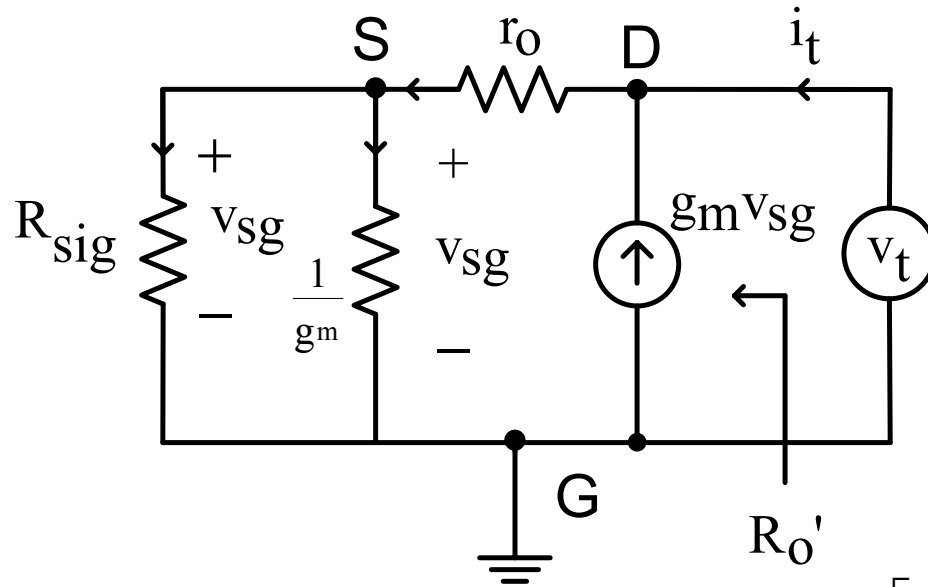

KCL at node D :

$$i_t + g_m V_{sg} = \frac{V_t - V_{sg}}{r_o}$$

$$i_t = \frac{V_t}{r_o} - V_{sg} \left( \frac{1}{r_o} + g_m \right)$$

$$i_t = \frac{V_t}{r_o} - \frac{V_t \left( \frac{1}{r_o} + g_m \right)}{\left[ \frac{1}{R_{sig}} + g_m + \frac{1}{r_o} \right] r_o}$$

$$i_t = \frac{V_t}{r_o} \left[ 1 - \frac{\left( \frac{1}{r_o} + g_m \right)}{\left( \frac{1}{R_{sig}} + g_m + \frac{1}{r_o} \right)} \right]$$

$$i_t = \frac{V_t}{150k} \left[ 1 - \frac{\left( \frac{1}{150k} + 1m \right)}{\left( \frac{1}{50} + 1m + \frac{1}{150k} \right)} \right]$$

$$i_t = 6.3471 \times 10^{-6} V_t$$

$$R_O' = \frac{V_t}{i_t} = 157.5528k\Omega$$

$$R_O = 15k // 157.5528k = 13.696k\Omega$$

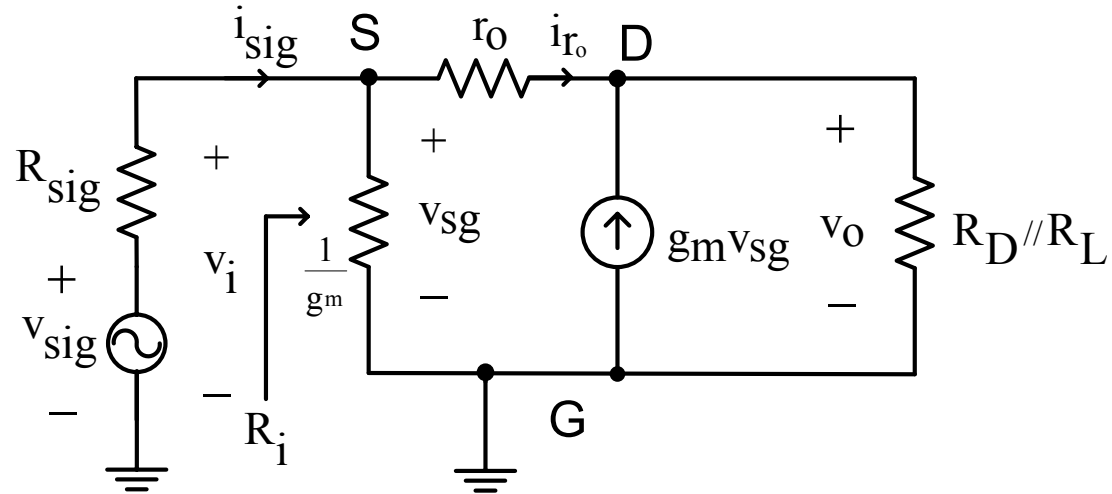

$$a_v = \frac{v_o}{v_{sig}}$$

$$v_o = \left[ \frac{v_{sg} - v_o}{r_o} + g_m v_{sg} \right] R_D // R_L$$

$$v_o \left[ 1 + \frac{R_D // R_L}{r_o} \right] = v_{sg} \left[ \frac{1}{r_o} + g_m \right] R_D // R_L$$

$$\frac{v_o}{v_{sg}} = \frac{\left( \frac{1}{r_o} + g_m \right) R_D // R_L}{1 + \frac{R_D // R_L}{r_o}}$$

$$\frac{v_o}{v_{sg}} = \frac{\left( \frac{1}{150k} + 1m \right) 7500}{1 + \frac{7500}{150k}}$$

$$\frac{v_o}{v_{sg}} = \frac{7.55}{1.05} = 7.1905$$

$$v_{sg} = \frac{R_i}{R_i + R_{sig}} v_{sig}$$

$$v_{sg} = \frac{1045.1245}{1095.1245} v_{sig}$$

$$v_{sg} = 0.9543 v_{sig}$$

$$a_v = \frac{v_o}{v_{sig}} = \frac{v_o}{v_{sg}} \frac{v_{sg}}{v_{sig}}$$

$$a_v = 7.1905 \times 0.9543$$

$$a_v = 6.8619$$